



Standards for Communications Infrastructure

Computing and Information Technology
Wayne State University
5925 Woodward
Detroit, Michigan 48202

Revised: April 2023

<https://tech.wayne.edu/docs/wsu-communications-standards.pdf>

Revision History

21 April 2023	Second publication of completely revised document. All sections rewritten. Page numbers and section labels have been re-ordered and revised.
1 December 2020	Page 60 Hybrid Blue Light Phone ADDENDUM B
26 July 2019	Changed CSI (Construction Specification Institute) section numbers to 27000 series. All sections renumbered. Added installation and system requirements for VOIP, wireless, security cameras. Also clarified building renovation project requirements, changed tester model, updated test specifications, revised format.
13 March 2015	Updated to add additional installation and system requirements for VOIP, Wireless access points, security cameras. Added Digital Signage, clarify renovated space requirements, revised tester requirements, test specifications, removed Multi Mode fiber requirements between buildings, etc.
13 February 2014	Updated to add new systems requirements, specifications, clarify wording, revised tester to be used, test specifications, numbers, bullets, etc.
31 October 2012	Updated to add and clarify systems requirements, specifications, clarify wording, remove redundant specifications, numbers, bullets, etc.
31 October 2010	Updated to include additional manufacturers of approved structure cabling systems, clarify wording, Add page numbers, fix table of contents page numbers, etc.
15 June 2009	Updated to include additional manufacturers of approved structure cabling systems.
29 April 2005	Updated to include exact manufacturer product names for approved Category 6e (cat6e) structured cabling system components. Add URL for online copy of this document in Adobe Acrobat (.pdf) format.
1 December 2004	First publication of completely revised document. All sections rewritten.
24 March 2003	Changed CSI section numbers to 17000. All sections renumbered.
12 July 2000	2nd publication of complete document. All sections complete.

30 April 1999 1st publication of complete document. CSI format sections in 16000 number series.

13 August 1998 Partial publication of standards document.

Contents

- Revision History 2**
- Acknowledgements..... 6**
- WSU Telecommunications Design Requirements 7**
 - 1. Applicable Standards..... 7**
- Specific WSU Requirements 7**
 - 1. Drawing Requirements/Deliverables..... 7**
 - 2. Renovated Area IT Requirements 8**
 - 3. Tenants in WSU Retail Spaces..... 9**
 - 4. Construction Administration 9**
 - 5. Systems and Performance 9**
 - 6. Outside Plant and Entrance Facilities 10**
 - 7. Grounding..... 11**
 - 8. Telecommunications Rooms (MDF, IDF)..... 11**
 - 9. Pathways..... 13**
 - 10. Fiber Backbone Cabling..... 13**
 - 11. Copper Horizontal Cabling..... 14**
 - 12. Security Cameras..... 14**
 - 13. Building Access Standards..... 16**
 - 14. Wireless access points..... 16**
 - Outdoor Wireless Access Points..... 18
 - Point-to-Point Bridges..... 18
 - 15. Emergency Phones 19**

Blue Light Phones	19
Blue Light phone with camera - wall mount	19
Blue Light phones - Existing.....	19
Blue Light Components:	20
Elevators.....	20
“Area of Rescue” Elevator Lobby Phones.....	20
Analog Gateways.....	20
Emergency Power for Emergency Phones (Analog gateway or VOIP)	20
Cable Infrastructure	21
16. IPTV in student lounges.....	21
17. OneCard Infrastructure Installation.....	21
18. Workstation Outlets	21
19. Jack Labeling	22
20. Testing and documentation	23
Section 27010 - Telecommunications general requirements.....	24
1. General.....	24
2. Execution.....	27
Section 27110 - Telecommunications interior pathways.....	31
1. General.....	31
2. Products	32
3. Execution.....	32
Section 27130 - Communication equipment spaces support hardware.....	34
1. General.....	34
2. Products	34
3. Execution.....	37
Section 27150 - Telecommunications cabling.....	39
1. General.....	39
2. Products	42
3. Execution.....	47

Section 27170 - Cable plant administration and testing..... 50

 1. *General*.....50

 2. *Products*50

 3. *Execution*.....50

Section 27600 – C&IT digital signage specifications 54

ADDENDUM A58

Acknowledgements

Mark Hamel, Network Plant Manager
Computing & Information Technology
5925 Woodward
Detroit, Michigan 48202-3555
Tel: 313-577-1525
<https://tech.wayne.edu>

C&IT Infrastructure and Operations

Juan Richardson, Senior Director, Infrastructure and Operations
Andrew Murrell, Director, Enterprise Networks
Kathy Guarano, Associate Director, Telecommunications

Frank Papp, Network Engineering & Security
Matt Lessins, Core Network Engineering
Gary Morris, Network Engineering & Security
Tim Muir, Wireless Networking & OneCard
Kim Parker, Construction Project Services
Carlo Musante, Core Network Engineering
Steve Wassef, Campus & Classroom Technology Services
Charles Zuber, Wireless Networking

Facilities Planning & Management (WSU)

Ashley Flintoff, Director
Edward Doyle, Director
Ekta Kamalia, Director
FP&M Design & Construction Services Team

Facilities Planning & Management
5454 Cass
Detroit, Michigan 48202
Tel: 313-577-4310
Fax: 313-577-1817
<https://www.facilities.wayne.edu>

Other sources

BICSI (Building Industry Consulting Service International)
Tim Bloch, RCDD - Structured Innovations
Kevin Davis, RCDD - Western TelCom
Paul Kreamer, RCDD - Compass Technologies
Tom Hilla, RCDD - Parallel Solutions, LLC

WSU Telecommunications Design Requirements

1. Applicable Standards

1. Unless specifically indicated otherwise in this document, all telecommunications infrastructure shall be designed in accordance with the following standards including all appropriate addendums and revisions:

ANSI/TIA-568-C	Commercial Building Telecommunications Cabling Standard
ANSI/TIA-606-B	Administration Standard for Commercial Telecommunications Infrastructure
ANSI J-STD-607-B	Commercial Building Grounding (Earthing) and Bonding Requirements for Telecommunications
ANSI/TIA-758	Customer Owned Outside Plant Telecommunications Cabling Standard
BICSI	Telecommunications Distribution Methods Manual (TDMM)
BICSI	Telecommunications Cabling Installation Manual (TCIM)
ANSI/TIA 569-C	Commercial Building Standards for Telecommunications Pathways and Spaces

Specific WSU Requirements

1. Drawing Requirements/Deliverables

1. All low voltage telecommunication drawings must state compliance with **WSU Standards for Telecommunication Infrastructure**. The main legend should contain "This drawing set must comply with WSU's Standards for Telecommunications Infrastructure (<https://tech.wayne.edu/docs/wsu-communications-standards.pdf>)."
2. The Architect/Engineer and/or General Contractor shall formally acknowledge having read and understand the "Standards for Telecommunication Infrastructure" and its specifications.
3. The IT components must be shown in their entirety on dedicated telecommunications page(s).
4. At project completion, provide as-built IT discipline component CAD drawings with each IT discipline on their own layer.

5. See **CSI format (Division 27-Communications)** specifications for cable, connectors, and cable management hardware as well as compliance to WSU standards for telecommunication infrastructure.
6. Drawings must show:
 - 6.1. Telecommunications room locations, dimensions, and zone plan indicating areas served by each room.
 - 6.2. Backbone riser diagrams indicating connectivity relationships between telecommunication rooms.
 - 6.3. “J” hook and cable tray pathways for backbone and horizontal cabling
 - 6.4. Intermediate Distribution Frame (IDF) telecommunication room grounding riser.
 - 6.5. Details of all grounding within the Main Distribution Frame (MDF) telecommunication room.
 - 6.6. Fiber optic cabling backbone riser cable type & strand count. In the case of a building renovation where existing riser cabling exists, the last 4 strands of any fiber cable cannot be used for the renovation project. If this condition exists, FP&M and C&IT must negotiate if 2 of the last 4 strands can be used or the project will install a new riser cable. If the existing fiber optic backbone cabling does not reach a relocated telecommunications closet a new cable must be installed from the origination point.
 - 6.7. Main cable tray size and pathway layouts.
 - 6.8. Identify all telecommunication component placement for typical spaces.
 - 6.9. Details of backboard elevations indicating space allocated for wall fields, equipment, etc.
 - 6.10. Details of rack elevations indicating all patch panels placement, cable management, structural supports, ground connections and space allocated for owner provided network electronics and any UPS/power conditioners.
 - 6.11. Details of telecommunications room plans indicating placement of racks, cable runway, and wall mounted systems and ground bus locations.
 - 6.12. Details of all intended pathways and raceways for horizontal and backbone cable. This includes outside conduits to blue light phones.
 - 6.13. Details of outlet configurations by unique symbol and/or schedule
 - 6.14. Identify all non-telecommunication component locations that interact or interface with telecommunication infrastructure. These items must be clearly shown on the IT component drawings. This is not debatable and must be identified.
7. To aid in placement of physical IT components designed by C&IT, a regularly updated Building Information Modeling (BIM) object file must be provided to the C&IT Project Manager through the duration of the project.

2. Renovated Area IT Requirements

1. At project initiation, the Project must audit and provide a report for C&IT review detailing all existing low voltage telecommunication infrastructure to be demolished prior to start of project to determine IT impacts.
 - 1.1. Existing low voltage telecommunication infrastructure that is to remain in-place must be identified and physically tagged to prevent disconnection/modification.
2. Existing telecommunication cabling which does not meet BICSI standards cannot be included in the project. New cable and or conduit must be installed.
3. At project initiation the Project must audit and provide a design detailing existing IT telecommunication room components and layout and proposed IT project impact including specific data counts to IT closets. This validation of existing IT room capacity and layout is required prior to project start.

3. Tenants in WSU Retail Spaces

1. It is strongly recommended that lease tenants build their telecommunication infrastructure adhering to the same WSU standards for telecommunication infrastructure.
2. Lease tenants must provide their own IT telecommunication interconnection between their telecommunication room / space and the WSU building MDF or third party dmarc.
3. If the lease tenant is a WSU affiliate / not for profit, WSU will provide ISP network connectivity. There cannot be any P.O.S. (point of sale) transactions on this connectivity provided.
4. If the lease tenant is not a WSU affiliate / or are for profit, they will need to purchase their own ISP network connectivity.
5. The university preferred vendors for ISP are AT&T and Comcast

4. Construction Administration

1. FPM & C&IT project managers will establish telecommunication guidelines for the project to follow.
2. Prior to any construction, installation, or modification of IT facilities or systems, it shall be the contractor's responsibility to document existing field conditions to establish a baseline in the work area. Field conditions shall include (but are not limited to) the physical condition of the existing telecommunications cabling, conduit, or facilities infrastructure, infrastructure electrical and optical performance, or any other site conditions, either above ground or underground that may be affected.
3. Method of documentation of existing conditions to be determined prior to any contract.
4. After construction, installation, or modification to IT facilities or systems, it is the Architect/Engineer responsibility to document final as-built conditions compared to the initial work area baseline.
5. It shall be the contractor's responsibility to restore or repair any damage or deviations from the initial baseline solely at their expense.
6. The FP&M and C&IT staff will make periodic construction visits to observe the installation for conformance to project specifications, proper installation practices and the adherence to C&IT standards for telecommunication infrastructure. Any out of compliance items shall be noted to the project team.
7. The FP&M and C&IT project managers will perform a final punch list of all telecommunication systems installed.

5. Systems and Performance

1. Designed to support a minimum of 1Gbps Ethernet to the desktop over CAT6E copper cabling.
2. Intra-building backbone shall support a minimum of 10Gbps Ethernet on OM3 50-micron multi-mode & Single Mode fiber cabling between telecommunication rooms.
3. Specific IT design and services that are outside the scope of this document are to be coordinated with C&IT.
4. Final design must be approved by C&IT.

6. Outside Plant and Entrance Facilities

1. Incoming Service Requirements

- 1.1. Provide a minimum of either one “Quazite” handhole that are 24” W x 42” D x 36” L with a minimum load rating of 15,000 lb or one 5’x5’x5’ concrete manhole / vault with a round cast iron cover manhole for building entrance facilities. These may be installed in a green space, sidewalk, or driveway area on the building property. Provide a minimum of three 4” conduits from this handhole or vault into the building MDF. A downward slope must be maintained to the manhole to prevent water from draining into the building. All conduits must be sealed at the pole or last manhole before entering the building to prevent rodents, water or gases from entering the building using fire rated foam or conduit plugs.
 - 1.1.1. The Architect/Engineer shall coordinate with C&IT and FP&M to determine final requirements. Final design shall be approved in advance by C&IT and FP&M.
 - 1.1.2. Concrete manholes/vaults shall be required on sidewalks accessible to vehicles, driveways, roadways or when building entrance facility capacity issues dictate need for a larger vault.
 - 1.1.3. Quazite hand holes can only be installed in greenspaces and when building entrance facility requirements are minimal.
- 1.2. Provide a minimum of three 4” conduits from the service entrance facility into the building MDF. Install one of the 4” conduits from the entrance facility to the property line tying into 3rd party service vendor manhole, tunnel, etc., one for WSU Backbone fiber cable, & one as an emergency maintenance spare. New building construction will be required to build out the backbone conduit infrastructure to tie into the main campus fiber backbone system. This applies to new construction or full building renovation. *Note that designated C&IT Main Hub buildings may require additional conduits. *
 - 1.2.1. Conduits shall be HDPE if buried underground. Steel or PVC conduit when cast in concrete. Exposed PVC conduit is only allowed overhead in parking structure decks.
 - 1.2.2. Coordinate with all third-party entities the pathway route from building/property to their respective manhole locations.
 - 1.2.3. Coordinate with C&IT for further definition of design requirements for WSU data or external service provider connectivity.
 - 1.2.4. A #6 AWG tracer wire must be installed in 4” conduit.
 - 1.2.5. The 4” third party conduit must be built to the property line. Third party owned manholes will not be installed on WSU owned property.

2. Manholes, Handholes

- 2.1. Provide additional manholes and/or handholes to minimize cable pulls to 400’, with a maximum of two 90-degree bends.
 - 2.1.1. In streets and driveways, provide 5’x5’x5’ concrete manhole with round cast iron cover.
 - 2.1.2. In sidewalks, provide 5’x5’x5’ concrete handhole with a round cast iron cover.
 - 2.1.3. In Green Areas, provide “Quazite” handholes that are 24” W x 42” D x 36” L.
 - 2.1.4. Locate Quazite handholes in green space only.
- 2.2. Provide a #6 AWG solid copper tracer wire in all exterior conduits for future conduit locating usage.
- 2.3. Upon completion, before final project sign-off by C&IT, the following must be provided:
 - 2.3.1. A site plan (in the form of CAD drawings and a BIM) of installed conduit showing conduit location, quantities and depth.

2.3.2. No exception to this will be allowed.

7. Grounding

1. Ground Bus
 - 1.1. Provide a minimum of ¼" x 2" x 2' ground bus in each IDF.
 - 1.2. Provide a minimum of ¼" x 2" x 4' ground bus in the MDF.
2. Bonding Backbone
 - 2.1. Provide a #4/0 AWG insulated copper bonding backbone from the main ground bus in the MDF service entrance to the IDF with #6 AWG jumper to TGB's.
 - 2.2. Do not route bonding backbone within 18" of electrical feeders.
3. Equipment
 - 3.1. Bond all racks, cabinets, armored cables, lightning protectors etc., to ground bus in each telecommunications room with #6 AWG insulated green jacket ground conductor.
4. Performance
 - 4.1. Maximum 2 ohms DC resistance.

8. Telecommunications Rooms (MDF, IDF)

1. Spacing Criteria
 - 1.1. Stack telecommunication rooms wherever possible. Telecom rooms must have the door open into a main hallway.
 - 1.2. Provide one telecommunication room for every 10-20,000 sqft. Verify telecommunication cable is less than 295 ft. in length to the farthest device.
 - 1.3. Cable length from telecommunication room to any device shall not exceed 295'. If this is the case, an additional telecommunications IDF must be built to serve the area.
 - 1.4. Centrally locate telecommunication rooms on a floor to minimize horizontal cable lengths and maximize the service area.
 - 1.5. Any new telecommunications closets / rooms built as part of construction or renovations must have the door open into a main hallway. No telecommunications closets / rooms can be installed inside of an existing room, office, etc. that restrict access by network staff.
 - 1.6. Any C&IT supported network equipment installed such as switches, fiber panels, patch panels, etc. will be considered a telecommunications room and must adhere to all C&IT requirements outlined in this document and must have C&IT authorization to be built.
 - 1.7. MDF Requires a minimum of two four-post racks. C&IT must approve rack type, layout, and quantity. If C&IT has designated the building as a core network fiber hub a larger footprint may be required.
 - 1.8. IDFs require a minimum of two / two-post racks. C&IT must approve rack type, layout, and quantity.
2. *Physical Security*
 - 2.1. Telecommunication rooms must have WSU OneCard electronics installed to control room access as well as a low light capable security camera.
 - 2.2. Telecommunication rooms will be fitted with the new WSU/Best lock key series # 8XXXX as an emergency bypass key only.

- 2.3. The final design layout must be coordinated with at least one person from WSU FP&M, WSU C&IT and WSU OneCard office with approval from C&IT.
- 2.4. One Card swipe access to telecommunications rooms will be authorized by C&IT.
3. Room Sizes
 - 3.1. Provide a minimum of one (10'x12') MDF per building. If designated as a core network fiber hub MDF room size will be (20'x20')
 - 3.2. Provide a minimum of one IDF telecommunications room per floor to meet the CAT6E 295-foot limit. Exceptions can be made for multi-story buildings with a small floor plan.
 - 3.3. 8' x 10' for telecommunication rooms serving (175) outlets or 3 racks, and 10 x12' for rooms serving between (176) and (325) outlets, or 6 racks.
 - 3.4. Adjust room sizes accordingly for additional systems (video, security, access control, etc.)
4. Layout
 - 4.1. Final room design must be approved by WSU FP&M and C&IT.
 - 4.2. Provide Fire Rated ¾" grade plywood. Do not paint.
 - 4.3. Telecommunication rooms must have either tile floors or sealed concrete.
 - 4.4. Provide minimum 2 racks per telecommunication room.
 - 4.4.1. Allow a minimum of 24" depth for rack equipment, 36" of clearance behind racks and 36" in front of racks.
 - 4.4.2. Allow minimum of 36" deep for equipment cabinets, 36" clearance behind racks and 36" in front of racks.
 - 4.4.3. Allow for 12" deep equipment on wall fields when calculating clearances.
 - 4.4.4. Provide 12" ladder rack around 3 sides of room and to each equipment rack.
 - 4.4.5. Ladder tray shall be secured to the top of the equipment racks.
 - 4.5. Doors shall always swing out and must be fitted with a door closer.
5. Lighting
 - 5.1. Locate lighting in front of and behind the racks, not above, at minimum height of 7'-6" AFF.
6. Provide 50fc lighting minimum at floor level.
7. Power
 - 7.1. Provide a dedicated 12 circuit panel board in the MDF telecommunication room for 120-volt 20-amp and 208-volt 30-amp single-phase circuits. This panel will supply service to the MDF and all IDF telecommunication rooms.
 - 7.2. Connect the above dedicated 12 circuit panel board to the building generator and/or building UPS. Design for full panel capacity.
 - 7.3. Provide dedicated feeder/riser for all telecommunication room dedicated panel boards. No other loads shall be served by this feeder.
 - 7.4. Provide a minimum of one 120-volt 20-amp dedicated circuit for each equipment rack.
 - 7.5. Provide a 120-volt, 20-amp, single phase "Managed" PDU/ Power Strip for the 120-volt circuit.
 - 7.6. Provide one additional 120-volt, 20-amp circuit for service outlets, one on each wall.
 - 7.7. Provide a minimum of one 208-volt 30-amp single phase dedicated circuit for each equipment rack. An additional circuit may be required pre-rack depending on the type and quantity of equipment installed. Terminate this circuit on a NEMA L6-30 Receptacle at the top of the equipment rack. Coordinate final location with WSU/C&IT.
 - 7.8. Provide a 208-volt 30-amp single phase "Managed" PDU/Power Strip for each 208-volt circuit.
 - 7.9. Provide 5U space at the bottom of each rack for owner provided rack mounted UPS and/or power conditioner.

8. Environmental
 - 8.1. Provide cooling based on a coordinated room by room design with C&IT.
 - 8.2. Utilize building cooling systems whenever possible.

9. Pathways

1. Backbone
 - 1.1. Provide a minimum of four 4" sleeves through Telecommunication room floors in stacked rooms and fire rated walls using the Hilti Speed sleeve system CP 653 BA. Any deviations from the Hilti sleeve systems for fire rated floors and walls due to special circumstances must be approved by C&IT Plant and FP&M. These sleeves shall be sized progressively smaller or less of them as you move away from the serving closet. Size will accommodate 30% growth after the cable is installed.
 - 1.2. Where rooms are not stacked, provide minimum two 4" conduits continuous between telecommunication rooms.
 - 1.3. Connect telecommunication rooms on the same floor with a minimum of one 4" conduit.
 - 1.4. Conduit between rooms shall have no more than two 90-degree bends and/or over 150' without a pull box. Pull boxes shall be sized per the number of conduits.
 - 1.5. Sleeves for standard / normal rated walls / non firewalls shall consist of the Specseal Ready sleeve system. (Part # STI FS100, STI FS200, or FS400) And must be installed to the manufacturer specifications.
2. Horizontal, accessible ceiling spaces
 - 2.1. Provide cable trays down corridors whenever possible. If cost prohibitive, J-hooks are acceptable. Provide J-Hooks for cable bundles of 24 and below.
 - 2.2. Route main cable runs through accessible corridor spaces and drop off into each room from the main runs.
 - 2.3. Do not route main cable trays or cable bundles through classrooms or offices.
 - 2.4. Maintain 12" minimum between cable tray and lighting.
 - 2.5. Terminate cable to the nearest telecommunication room on the same floor. Only in special cases will the horizontal cable terminate in a telecommunication room on a different floor. Coordinate this location with FP&M, C&IT project manager, & Plant Manager.
 - 2.6. Sleeves are used in standard walls and floors with no fire rating. All sleeves through the floor are to extend 4 inches above floor, unless otherwise noted. Provide escutcheons at each sleeve in finished areas and adequate spacing between sleeves to accommodate escutcheons. Specseal Ready sleeve system. (Part # STI FS100, STI FS200, or STI FS400) And must be installed to manufacturer specifications. All fire rated walls or floor cores riser systems must use the Hilti CP 653 BA sleeve system. If special circumstances exist that alter these preferences, please contact C&IT Plant Manager.

10. Fiber Backbone Cabling

1. Inter-building (Between building hubs)
 - 1.1. 96 strand single mode (glass fiber as manufactured by Corning) between hub buildings.
 - 1.2. Typical fiber cable is SMF28e or equivalent. Use G.652.C type cable for any repair.
 - 1.3. Provide a tagged / labeled 15' service slack loop in telecommunications room.
 - 1.4. Provide a tagged / labeled 30' service slack loop in manhole.
2. Inter-building (Between building hub to endpoint)

- 2.1. 48 strand single mode (glass fiber as manufactured by Corning) between hub and endpoint buildings.
- 2.2. Provide 15' service slack loop in each telecommunications room.
- 3. Intra-building
 - 3.1. Minimum 12 strand multi-mode (om3) and 12 strand single mode fiber riser cable between MDFs and IDFs.
 - 3.2. Provide a tagged / labeled 15' of service slack loop at each telecommunication room end.

11. Copper Horizontal Cabling

- 1. Provide cable and connectors only from WSU preferred manufacturers list.
- 2. Always install Category "6E (enhanced)" UTP cable.
- 3. Terminate on its own patch panel in equipment rack.
- 4. All non-security or non-BAS cables shall be green.
- 5. Building Automation System (BAS) data cables and patch cables shall be blue in color.
 - 5.1. Security camera cables shall be purple/violet.
- 6. Data Outlet
 - 6.1. Jacks shall be orange located in the outlet bottom position (vertical) or the outlet right position (horizontal)
 - 6.2. For non-security data connections, provide two gray patch cords per data outlet, installed.
 - 6.3. For security camera connections, provide two purple/violet patch cords per camera outlet installed. Outdoor locations require an outdoor rated patch cord (Black Allowed).
- 7. Cabling and jacks shall not be painted, coated, or fireproofed in any manner, and shall be protected during any building painting or finishing processes.
 - 7.1. Any repairs, cleaning, or replacement shall be at the contractor's expense.

12. Security Cameras

- 1. All security camera designs and installations must be reviewed and approved by WSU Public Safety and C&IT Prior to installation.
- 2. Typical and common camera locations (for reference only)
 - 2.1. All ingress/egress areas, exterior perimeter of building and approaches, elevator lobbies, elevator cab interior, common/high-use hallways, stairwells, blue light phones, money handling, vending areas, or mail areas, front desk/customer interaction areas, special needs areas, (high value items such as book collections, mineral museums, artwork), nuclear material, poisonous material storage, wet classrooms/laboratories & all telecommunications closets.
 - 2.2. Final camera design may include all, but is not limited to, the typical and common locations. Final design must be approved by WSU Public Safety, Office of Environmental Health, and Safety (OEHS), Risk Management, and C&IT.
 - 2.3. Please see **Addendum A** for additional details on Hybrid Blue Light Phone installations.
- 3. Installing contractor and their technicians must be certified in the camera product they are installing to ensure proper configuration, installation, and warranty.
- 4. Proof of certification shall be provided in advance by the contractor.
- 5. Cameras are to be stored safely, clean, and protected from damage and will remain boxed prior to installation on the job site. Any un-boxed cameras may be subject to replacement at the contractor's expense.
- 6. Wayne State Public Safety require that all cameras be fully functional and not be installed in advance of the C&IT Camera Team final walkthrough. The purpose of this walkthrough is to

- make sure that all construction activities have completed, (i.e., drywall, painting, flooring etc.). The project will contact the Camera Team who will conduct this walkthrough.
7. All security camera models will be verified with the WSU Camera Team prior to the cameras going to bid.
 8. Camera video surveillance licenses for viewing the cameras within WSU Public Safety will not be ordered or purchased prior to three months of the project completion date.
 9. The Security vendor must purchase the cameras then provide all camera MAC addresses and location on a C&IT-provided spreadsheet template to the Camera Team. The Security Vendor will program and apply the latest firmware upgrade available from the camera manufacturer. Before a request for IP address can be given out, the installing vendor must submit a spreadsheet with the following: camera name, location, jack/panel ID, IDF/ MDF connected in, make, model, and serial number/ MAC address.
 10. All security camera systems, new, modified or inherited must be compatible with the WSU video management system for WSU Public Safety access.
 11. Final design must be approved by WSU Public Safety, Office of Environmental Health and Safety (OEHS), Risk Management, and C&IT. Any inherited or remodeled camera systems with camera models or equipment older than five years old (At the time the construction commences) must be updated and replaced with newer camera models.
 12. All security cameras specified in the design must comply with the hardware compatibility list of the WSU VMS (video management system). The current list is available for design upon request from C&IT Network Engineering. All cameras must be 1080p or better.
 13. If any alterations are made after the original approval to the design, they must also be approved by WSU Public Safety, Office of Environmental Health and Safety (OEHS), Risk Management, and C&IT. Any changes in original approved camera models must be approved again by C&IT. Any permanent deletions of approved camera locations must have WSU Public Safety and C&IT approval. Modifications must be time / date stamped and submitted in writing.
 14. Any exterior mounted camera or pole mounted camera must be designed and mounted to minimize image movement. This must be designed in conjunction with and approved by WSU Public Safety, WSU FP&M and C&IT Network Engineering.
 15. Lightning protection is required for all outdoor cameras. The protection must have its own ground wire to the ground bar, labeled, and be installed on the backboard in the closet before the patch panel where the cable run terminates. Daisy chaining of ground wires is not permitted.
 16. Always install Category "6E (enhanced)" UTP cable. Violet or purple for indoor location.
 17. Hybrid Cable to all outdoor cameras and wireless access points beyond the 295' CAT6E distance limit. Hybrid cable is from Camera to nearest building MDF. Hybrid cable properties are 6 strand single mode fiber and a minimum two conductor 12 AWG copper hybrid cable. Depending on distance a larger AWG may be required.
 18. Cable and patch cords shall be purple and the jacks orange. A jack must be installed at the camera end and the jack must be the proper color and labeled properly.
 19. Any inline cable devices (POE extenders, lightning arresters, power injectors, etc.) used in a video camera or wireless access point installation must not limit the cable's data throughput capabilities and must be labeled to match the camera / wireless location. The product make and model must be approved by C&IT Network Engineering.
 20. Final camera view position, placement and image quality must be approved by WSU Public Safety and C&IT Network Engineering.
 21. All cameras – including cameras that are required to be in an outdoor housing – must be labeled to allow viewing from ground level. The label must contain the last two octets of the Ip address

- that is programmed into it (example: CAM-108.199). The label of the corresponding jack and patch panel must match the camera label.
22. All junction boxes containing a cable run with an inline device must also be labeled to match the camera cable patch panel side.
 23. When installing outdoor cameras, access points or any type of network device, you must use Hi-impact jacks and patch cords.
 24. All cameras are to be mounted in a location and manner that does not require special equipment to access and service. All cameras mounted to a drop ceiling infrastructure are to be secured to a solid support within or above the tile system using a BICSI or NEC approved method. No direct mounting to ceiling tiles will be permitted. All outdoor camera locations and any locations exposed to extreme temperature changes and weather elements consisting of underground conduit and above ground conduits shall have outdoor rated cable and outdoor rated inline accessories installed (as needed). This includes semi enclosed outdoor spaces (parking structures, overhangs, blue light, etc.). Any exceptions must be in writing and approved by WSU Public Safety and C&IT.
 25. All indoor and outdoor power injectors, ethernet extenders, and lightning protectors must be clearly labeled to match the corresponding camera location patch panel cable label. Any junction boxes that house this equipment must also be clearly labeled from the outside to show what locations are inside the box. Provide cable and connectors only from WSU preferred manufacturers list.
 26. Provide two (2) dark purple or violet patch cords per indoor camera outlet installed. Provide one (1) dark purple or violet patch cord and one (1) outdoor rated patch cord for outdoor or wet camera locations. The outdoor patch cords shall coincide with the camera manufacturer's recommendations or better. Any camera located outside must have an outdoor rated patch cord and must route through POE capable lightning protection before connecting to any network equipment. Any camera or device must have all required associated components installed (e.g., Axis Push- pull connectors must be installed on PTZ / Q6000 Series cameras).
 27. Per WSU Public Safety video policy standards, any disparaged nonfunctioning cameras are to be removed as part of the new installation.

13. Building Access Standards

1. Building access controls – WSU Public Safety Department
 - 1.1. WSU Public Safety owns and has all authority over all building access controls using the WSU PD approved and preferred vendor for the access control system. This includes WSU PD approved door station installations.
 - 1.2. All requests from entering campus buildings that are usually locked from the exterior of a building must be approved by WSU PD's Chief of Public Safety.
2. Door access solutions that require video surveillance must use an approved product with a video camera that integrates with WSU Public Safety's Video Management System. Approved Door Access Solutions that require video surveillance will be determined by WSU Public Safety.

14. Wireless access points

1. All wireless designs must be requested, reviewed, and approved by the C&IT Wireless team prior to ordering of any wireless equipment. This would include Access Point placements, models and corresponding mounting hardware.
2. When planning for wireless, C&IT plans for density first and coverage second.

3. Preferred installations shall be in classrooms or study areas, when designing for density.
4. Within the base design, locations including storage areas, maintenance/mechanical rooms, restrooms, stairwells or some outdoor spaces will not be covered by C&IT initial design unless requested by the customer.
5. All wireless designs shall meet 802.11ax requirements and meet an overall specification for minimal signal overlap value of -62 dBm everywhere density and coverage are needed. Density calculations will be used for the following types of areas:

Type of area	Devices per person
Student	3-4
Conference space	2
Staff	2
Research intensive	3
Housing	4-5

6. Depending upon where there is line of sight from the Access Point, intrusions of signals within the frequency, degradation of signal strength due to building architecture or other building materials, placement of Access Points will deviate, by C&IT Wireless Engineering authorized exception, from this standard by increasing in Access Point density.
7. Wireless access points will be placed a minimum distance of 12 feet and maximum of approximately 50 feet away from each other, the closer the better for density. 30-40 feet preferred for all installations.
8. All indoor rated Access Points shall be below ceiling, mounted in a downward-facing orientation. All wireless access points mounted to a drop ceiling infrastructure are to be secured to a solid support within or above the tile system using a BICSI or NEC approved method. No direct mounting to ceiling tiles will be permitted. Exceptions to this must be authorized by C&IT Wireless Engineering.
9. Hard ceiling mounted wireless Access Points are to be mounted to a square 4"x4" deep gang box. No round light fixture gang boxes. No round mud rings allowed.
10. ALL wireless Access Points located in Open or Exposed Ceiling Concept areas, must be mounted to a threaded rod or conduit mount to the unistrut, and located below any mechanicals, pipes, ducts, at a height of no less that 10ft, and no higher than 15ft from the floor.
11. All Access Points will be mounted with product mounting brackets approved by the wireless vendor.
12. Typical mounted Access Point height shall be between 8 to 10 ft AFF. Exception to this is only authorized by C&IT Wireless Engineering or if it is not possible due to an extended height ceiling.
13. Terminate the access point jack on the auxiliary systems patch panel in the rack, not in the data panel.
14. All wireless horizontal cabling shall be labeled by access point location naming convention, not by jack number. (EX: WAP-H### or WAP-Rm### or Outdoor EX: WAP-O-location)
15. Provide cable and connectors only from WSU-preferred manufacturers list.
16. Provide two grey patch cords per wireless outlet installed.
17. Patch cord length shall be consistent with installed wired network installation and design per wireless outlet jack installed.
18. Hybrid Cable to all outdoor Wireless Access Points beyond the 295' CAT6E distance limit. Hybrid cable to be installed to nearest building MDF. Hybrid cable properties are a 6-strand single mode fiber and two conductor 12AWG copper hybrid cable.
19. Provide a 15-foot cable slack loop in the ceiling or as close as possible to the jack location end.

20. All cable installed, patch cords, jacks and patch panels must be same manufacturer and product series.
21. Access point mounting and patch cord security will be identified on a case-by-case basis in the C&IT Wireless Engineering access point design.
22. Access point procurement, configuration and labeling will be done by C&IT Wireless Engineering. This ensures inventory control and prevents duplicate location deployment.
23. Installation of access points will be in the low voltage telecommunications cabling contractors' scope of work.
24. Data activations for the access points (patch panel cross connect to the network switch) will be done by C&IT Network Engineering.

Outdoor Wireless Access Points

25. All permanent outdoor wireless installations require Outdoor CAT6e infrastructure cabling (if under the length limit), ruggedized network connectors, and Outdoor rated Access Points only.
26. All outdoor mounted network devices such as access points and cameras must be grounded properly and attached to a lightning arrester before connecting to the network. Any inline cable devices (POE extenders, lightning arresters, power injectors, etc.) used in a video camera or wireless access point installation must not limit the cable's data throughput capabilities and must be labeled to match the camera / wireless location. The product make and model must be approved by C&IT Network Engineering.
27. ALL outdoor wireless installations will require silicone sealant for all fittings and firestop for wall penetrations.
28. Outdoor wireless wall mounted installations require the following parts, per each instance:
 - 28.1.Qty. 1 = Carlon 15005-100 ½" L/T FLEX PVC Conduit. This is the flexible conduit used to weather protect the cabling from the elements.
 - 28.2.Qty. 1 = Appropriate wall penetration flange, to be installed and silicone sealed to prevent water leakage.
 - 28.3.Qty. 2 = Bridgeport 430-NMLT ½" STR L/T connector. This is the connector to the ends of the flexible conduit. Used to connect the wall plate to the conduit end.
 - 28.4.Qty. 1 = Thread Adapter M20 to ½" NPT. This adapter allows proper sealed connection from the flexible conduit to the access point.
29. C&IT Wireless Engineering must approve any deviation from the above bullets.

Point-to-Point Bridges

30. Any Point to Point (PTP) or Point to Multi-Point (PTMP) bridge installed as a temporary solution must be approved by C&IT network engineering as an authorized exception. This must happen prior to the start of the project. PTP/PTMP bridges have minimum and maximum distance limitations and line of sight concerns that must be determined and approved by C&IT prior to approval of installation.
31. The permanent solution must be reviewed and approved by C&IT Network Engineering as a final installation solution before the temporary solution is allowed to be implemented.
32. Any PTP/PTMP bridge design or device being enacted on campus shall be designed by C&IT Network Engineering to prevent interference of WSU bridge devices already in place.
33. All outdoor mounted network devices such as access points, PTP/PTMP bridges, & cameras must be grounded properly and attached to a lightning arrester before connecting to the network. Any inline cable devices (POE extenders, lightning arresters, power injectors, etc.) used in a wireless bridge, video camera & wireless access point installation must not limit the cable's data throughput capabilities and must be labeled to match the camera / wireless location. The product make and model must be approved by C&IT Network Engineering.

34. All final area designations within a design must be approved and agreed upon by C&IT Network Engineering.
35. Provide cable and connectors only from WSU-preferred manufacturers list.
36. Patch cord length shall be consistent with installed wired network installation and design per wireless outlet jack installed.
37. All outdoor installations require Outdoor CAT6e infrastructure cabling if under the length limit, ruggedized network connectors, & rated for a wet environment.
38. Provide a labeled 15-foot cable slack loop on the roof/wall or as close as possible to the jack location end.
39. All cable installed, patch cords, jacks and patch panels must be same manufacturer and product series.
40. PTP/PTMP Bridge procurement, configuration and labeling will be done by C&IT Network Engineering. This ensures inventory control and prevents duplicate location deployment.
41. Installation of access points will be in the low voltage telecommunications cabling contractors' scope of work.
42. Data activations for the PTP/PTMP Bridges (patch panel cross connect to the network switch) will be done by C&IT Network Engineering.

15. Emergency Phones

1. Emergency phones include elevator, Area of Refuge/Rescue, and Blue Light phones.
2. Emergency phones on campus that are analog, Ramtel model 733 will need to be upgraded to the Talkaphone model as part of renovations and or new construction.
3. Emergency phones will be upgraded when new construction or renovation project occurs.
 - 3.1. Blue Light phone will upgrade to TalkAPhone (VOIP) device.
 - 3.2. Elevator phone will remain analog, supported by Centrex in buildings with existing AT&T service, or VOIP on analog gateway for new construction.
 - 3.3. 4-hour minimum power backup (UPS) is required, per City of Detroit Building Code.
 - 3.3.1. Four-hour minimum power backup (UPS) is required where no generator or emergency power is provided by others.
4. FP&M will continue to supply the emergency phone equipment and installation via contractor.

Blue Light Phones

5. New Blue Light phones will be VOIP technology, with Talkaphone as the approved manufacturer. Existing emergency phones without impacting renovation plans will continue to be supported by Centrex. These locations will be converted as time and budget allow.
 - 5.1. Four-hour minimum power backup (UPS) is required where no generator or emergency power is provided by others.
 - 5.2. Please see **Addendum B** for additional details on Hybrid Blue Light Phone installations.

Blue Light phone with camera - wall mount

6. For new sites that require building wall mounted Blue Light phones, the Talkaphone enclosure part number is ETP-WMS-OP2-OP31P.

Blue Light phones - Existing

7. When a renovation project impacts an existing Blue Light, this phone must always remain operational unless an alternative plan is negotiated with C&IT and WSU Public Safety prior to de-

activation or removal. The legacy Ramtel blue light phone is to be retired and replaced with a VOIP-500E Talkphone Blue Light phone / stanchion.

Blue Light Components:

8. WSU specific information required when ordering stanchion from vendor:
 - 8.1.1. PMS 281 Midnight Blue
 - 8.1.2. White EMERGENCY lettering
 - 8.1.3. 120v
 - 8.1.4. Custom wireless access point mounting pole required.
 - 8.1.5.** Cut sheet part number: **ETP-MT/R-OP4P-PCS**
 - 8.1.6. Contractor or the project placing the order must verify with Talkphone that the Wireless & Camera mounting pole / bracket is included in order.

Elevators

1. These devices are supplied by FP&M and currently require analog connectivity. At present these devices will be supported by analog gateway or existing Centrex line, as noted in Section 16.3.2.

“Area of Rescue” Elevator Lobby Phones

1. These devices are supplied by FP&M and require an analog connectivity. At present these systems will be supported by analog gateway or existing Centrex line, as noted in Section 16.3.2.

Analog Gateways

1. When AT&T Centrex service is not available, a specified analog gateway will be configured by C&IT, ordered by the project.
2. All analog device systems — new, modified or inherited — must function with WSU analog gateway infrastructure.
3. Analog Gateways will be physically located in the building’s MDF, or closest buildings MDF.
4. Analog Gateways in IDFs are considered an exception and a non-standard configuration.
5. Additional copper tie cable infrastructure may be required to interconnect the IDF to the analog gateway phone if the MDF is where the analog gateway equipment is located.

Emergency Power for Emergency Phones (Analog gateway or VOIP)

1. Buildings with generator power shall include:
 - 1.1. Connectivity from device to analog gateways (MDF)
 - 1.2. **10-minute** UPS battery backup to support analog gateway and network switch power.
 - 1.3. Dedicated 208v circuit
2. Buildings without generator power shall include:
 - 2.1. Connectivity from device to analog gateways (MDF)
 - 2.2. **Four-hour** UPS battery backup to support analog gateway and network switch power.
 - 2.3. Dedicated 208v 30A circuit

Cable Infrastructure

1. Cabling for emergency / blue light phones shall be:
 - 1.1. If under 295' from the MDF install three appropriately rated Cat6E network lines: one for voice, one for video surveillance camera and one for optional camera or wireless technology.
 - 1.2. If distance exceeds this limit or cables terminate in another closet, copper riser cabling may need to be installed between emergency phone jack termination IDF and MDF where analog gateway is located as well as using method 2.
 - 1.2.1. Method 1 – 3 CAT6E outdoor rated cables from MDF to stanchion less than 100 meters.
 - 1.2.2. Method 2 –Over 295 feet from MDF install a 6 strand SM fiber & 2 conductor 12 awg minimum copper hybrid cable from MDF to stanchion. A larger AWG may be required depending on distance.
 - 1.2.2.1. NOTE: Method 2 does not require 120-volt AC service to the Blue Light Phone stanchion. It does require a 4-hour UPS or dedicated building generator circuit installed at closet termination point.
 - 1.3. Terminate copper data lines to lightning protection on the fire rated backboard then on the patch panel designated "Emergency phones."
 - 1.4. Cable Jacket for outdoor CAT6 specification will be black.
 - 1.5. Terminate with 568B connections.

16. IPTV in student lounges

1. Roku device permanently mounted behind the TV.
2. Mount on the wall, next to the TV, a 7" touch screen Crestron user interface that will control TV off/on, volume, and channel changes.
 - 2.1. Supported device 7-inch touch screen Crestron control system TSCW-730

17. OneCard Infrastructure Installation

1. All OneCard design, hardware, software and installations must be coordinated and approved by Business and Auxiliary Operations – IT Business Operations Department and Computing & Information Technology – Network Services Department.
2. OneCard equipment will be in its own enclosure(s) in C&IT telecommunication rooms.
3. OneCard equipment is never to be co-located in enclosures with any other equipment and must be clearly labeled.
4. OneCard equipment will require its own dedicated 120volt 20-amp circuit.
5. All One Card network connections require their own data jack to be installed labeled with the pretext AC (Ex: AC-201-D01). No long-extended patch cords are allowed.
6. No exception to any of these requirements will be allowed.

18. Workstation Outlets

1. General
 - 1.1. Unless noted otherwise, a typical outlet shall consist of one (1) data outlet.
 - 1.2. Every enclosed space 8 feet by 10 feet shall be provided with a minimum of one (1) Data outlet.

- 1.3. The data cable installed in the wall shall be green and jacks shall be orange.
2. Classrooms
 - 2.1. Provide (1) D at each FSR box in the front of the room.
 - 2.2. Provide (1) VOIP Wall phone near door per risk management, OEHS, or State / Federal law requirements.
3. Offices
 - 3.1. Provide (1) D at each desk location. For an office with one desk, typical corner opposite door unless furniture layout or program statement Indicates otherwise.
4. Conference Room
 - 4.1. A conference room table of 10 seats or more, provide (1) 2" sleeve through the floor to the table for multimedia connectivity. Determine in the design if this is needed and or required by customer for any conference room table seating less than 10 on premises.
5. Public Spaces
 - 5.1. Provide (1) D for each vending, copier, ATM or any other network device.
6. Engineering Buildings
 - 6.1. Provide (1) D for a typical outlet unless otherwise noted.
7. Research Buildings
 - 7.1. Provide (2) D at selected locations. This will provide the ability to provide 2 different types of network connectivity. This must be verified with the customer, coordinated with the FP&M project manager and the C&IT project manager.
8. Dorms and Apartments
 - 8.1. Provide (1) data in each bedroom and (1) data in the common Room. This will provide data network connectivity only.
9. Labs
 - 9.1. Use specific user requirements or outfit as a typical classroom.
10. Furniture Coordination
 - 10.1. Provide (1) D per cubicle. Outlets must be mounted in the furniture provided raceway or on the wall. Double stick for mounting or outlets lying on the floor are not acceptable.
 - 10.2. Voice/Data jacks mounted on the wall will require voice/data patch cords installed through systems furniture cable raceways, or they can be wired permanently with a cable whip from the wall, ceiling or floor to the systems furniture.
 - 10.3. Patch cords routed through furniture must be the correct length. No couplers putting two patch cords together are allowed. No field-built patch cords allowed. Must be labeled on both ends to appropriate jack location.
 - 10.4. This installation must comply with NEC code specifying low voltage and high voltage cables must be separated by a divider channel.
 - 10.5. It is the responsibility of the telecommunications cabling contractor to meet this standard and install correctly.
 - 10.6. WSU / C&IT / IT Customer Services / Telecommunication cabling vendors and or technicians will not fish any wire or patch cord through systems furniture raceway. They will NOT cut any holes, remove knock outs, provide or install jacks and faceplates in the systems furniture. The furniture layout must not block the outlet on the wall. If this condition exists, the furniture must have an access panel, or the outlet must be wired into the furniture.

19. Jack Labeling

1. Workstation Data Jack
 - 1.1. [Room Number] or [Cubicle Number]- [Function + multiple jacks in room number].
 - 1.1.1. Ex: 222-V01, 222-D01, 222-V02, 222-D02, 223-V01, 223-D01, etc.
2. Security Cameras

- 2.1. Security camera jacks labeling scheme is [CAM] - [Last 2 octets of the IP Number].
3. Wireless Access Points
 - 3.1. WAP- [room number]. If in the corridor, use the closest room number.
 - 3.2. Access points shall be labeled at the access point and the patch panel by location/jack number, not with just a jack number.
 - 3.3. Example of labeling = WAP-H### or WAP-Rm### or Outdoor
 - 3.3.1.Ex: WAP-O-location
 - 3.4. Final labeling will not use temporary or pending room numbers that appear on construction documents.
4. Fiber LIU Panels
 - 4.1. For backbone cables between hub buildings, [cable location type]- [WSU Building Number] [Fiber Type & Count]. Example: BC-193-SM144 = hub to hub inter-building backbone cable for building 193.
 - 4.2. C-062-SM48 = hub to endpoint inter- building backbone cable for building 062.
 - 4.3. RC-193-SM96 = inter- building redundant backbone cable for building 193.
 - 4.4. BRC-027=building riser cables between telecommunication rooms, [cable location type]- [WSU Building Number]- [floor number]- [telecommunication room number] [Fiber Type & Count].
 - 4.4.1.Ex: BRC-027.03.IDF315-MM24.
 - 4.5. In the case of a building renovation where existing riser cabling exists, the last 4 strands of any fiber cannot be used for the renovation project. If this condition exists, FP&M and C&IT must negotiate if 2 of the last 4 strands can be used or the project will install a new riser cable. If the Telecommunication closet moves to another location a new fiber optic cable must be installed. Repurpose of old cabling not permitted. Contact C&IT for fiber cable type.

20. Testing and documentation

1. Testing Criteria
 - 1.1. Comply with TIA testing requirements.
 - 1.2. To be done by the cabling installation contractor. They must be certified to install the product line chosen. No exception to this will be allowed.
 - 1.3. All items tested must comply with manufacturer testing requirements and specifications.
 - 1.4. Test results will demonstrate compliance with all parameters of manufacturer's stated performance.
2. Documentation
 - 2.1. Upon completion, before final payment the following must be provided.
 - 2.1.1. Provide the manufacturer warranty certificate upon completion.
 - 2.1.2. Provide (1) electronic copy of test results in PDF file format along with final as built prints.
 - 2.1.3. No exception to this will be allowed.

Section 27010 - Telecommunications general requirements

1. General

1. Drawings

- 1.1. The drawings must show the location of equipment racks and elevations, ladder rack on 3 walls, power outlet locations, general arrangement of equipment, electrical systems and related items. The installation will follow as closely as elements of the construction will permit.
- 1.2. The drawings must show a conduit and cabling riser diagram from MDF and related IDFs. Copper pair and fiber strand counts will be detailed showing the distribution of riser cabling between the MDF and related IDFs.
- 1.3. Deviations from the drawings, except for minor changes in routing and other such incidental changes that do not affect the functioning or serviceability of the systems, shall not be made without the written approval of the architect/engineer and WSU C&IT.

2. Inspection of Site

- 2.1. Visit the site, examine and verify existing telecommunications infrastructure conditions under which the work must be conducted before submitting proposal.
- 2.2. The submitting of a proposal implies that the Contractor has read the WSU Telecommunications Standards document, visited the site, and understands the conditions under which the work must be conducted.

3. Contract Breakdown

- 3.1. WSU Facilities Planning and Management retains the installation and coordination for all projects initiated by that department. WSU C&IT retains the design review, installation and coordination for all other voice, data and video projects not initiated by WSU Facilities. For Mac work WSU Facilities will send all test results and telecommunication as-builts to C&IT Plant & Infrastructure upon completion and before data activation requests can be processed.

4. Guarantee

- 4.1. Contractor guarantees that the installation is free from defects and agrees to replace or repair, any part of this installation which becomes defective within a period of two year following final acceptance, provided that such failure is due to defects in the equipment, material or installation or to follow the specifications and drawings. File with the owner any and all guarantees from the equipment manufacturers and warranty certificates. FP&M will notify C&IT of substantial completion and deliver all warranty certificates, as-builts and test results. This warranty will coincide with the project warranty.

5. Codes, permits, and fees.

5.1. Unless otherwise indicated, all required permits, licenses, inspections, approvals and fees for telecommunications work shall be secured and paid for by the contractor. All work shall conform to all applicable codes, rules and regulations.

5.2. All work shall be executed in accordance with the rules and regulations set forth in local and state codes. Prepare any detailed drawings or diagrams which may be required by the governing authorities. Where the drawings and/or specifications indicate materials or construction in excess of code requirements, the drawings and/or specifications shall govern.

6. Standards of materials and workmanship

6.1. All materials shall be new, never used, reused, reconditioned, or refurbished components. The electrical and physical properties of all materials, and the design, performance characteristics, and methods of construction of all items of equipment, shall be in accordance with the latest issue of the various, applicable Standard Specifications of the following recognized authorities:

A.N.S.I.	American National Standards Institute
A.S.T.M.	American Society for Testing Materials
BICSI	Building Industry Consulting Services International
I.C.E.A.	Insulated Cable Engineer’s Association
I.E.E.E.	Institute of Electrical and Electronics Engineers
N.E.C.	National Electrical Code
N.E.M.A.	National Electrical Manufacturer’s Association
TIA	Telecommunications Industry Association
U.L.	Underwriters Laboratories, Inc. NFPA National Fire Protection Agency

6.2. All equipment of the same or similar systems shall be by the same manufacturer.

7. Record drawings

7.1. Architect/Engineer to provide revised telecommunications working drawings indicating “as-built” conditions. Drawings shall include all changes that have occurred during construction. Identify all backbone and horizontal wiring pathways.

7.2. Locate all network and workstation devices. Identify all devices on plan with proper labeling. Identify outside plant backbone conduits, manholes and fiber cables installed on a site plan. “As-built” drawings shall be submitted to the C&IT project manager & Plant Manager on AutoCAD 2018 or newer electronic DWG file format.

7.3. Provide a site plan with elevations showing any manholes, handholes or conduit installed outside.

8. Shop drawings/submittals

- 5.1 All shop drawings shall be submitted in groupings of similar and/or related items (cable and connectors, equipment cabinets and racks, etc.). Incomplete information will cause the submittal to be rejected and will require resubmittal before approval.
- 5.2 The bid drawings must show detailed layout of backbone and horizontal cabling distribution. This includes pathways, equipment room layouts, details, and related information necessary of installation and maintenance. After review by FP&M and C&IT, a copy of Drawings will be stamped and returned to the project manager, then distribution to the project team.
- 5.3 Submit for approval all applicable telecommunications systems prior to any equipment/materials being purchased or installed. These items are referred to by symbolic designation on the drawings and specifications. All submittal line items represented on the drawings should have matching product (make/model/etc.) information. Refer to other sections for equipment specification requirements. Submittals are required for the following:
- Copper & fiber structured cabling, system components, & fire rated sleeves
 - Structured cable system raceways and supports.
 - Outside plant cabling and components
 - Outside plant ducts manholes, hand holes and conduit systems on a to scale site plan.
 - Equipment racks and cabinets including wire / fiber management components.
 - Label copper patch panels & fiber LIU equipment
 - Telecommunication room equipment rack, cable tray & armored cable grounding components
 - Conduit, inner duct, junction and pull boxes.
 - Surface raceway components
 - Manholes, hand holes and all accessories
 - Telecommunication room telephone system components
 - Data network system components
 - Audio/video cabling, system components, rack elevation diagrams & FSR Box size and contents required.
 - Access control system components
 - Security Camera system components
 - Riser Diagram and Sleeves

6. Contractor bid eligibility qualifications

- 6.1 The installing contractor for each telecommunications system shall have a minimum of 5 years of experience with the types of systems specified. The company and employee must be certified to install, test and warranty the product specified. This certification must be produced at the WSU mandatory pre-bid meeting, prior to a bid submittal. **No exception to this will be allowed.**

6.2 The installing contractor may be asked to submit a reference list consisting of a minimum of **3 - 5** installations of equivalent size and complexity of this contract. The reference list shall contain the following information for each installation:

6.2.1 Name of project, square footage, location and brief description of systems.

6.2.2 Date of completed installation.

6.2.3 Contact name and phone number of facility representative.

6.2.4 Total bid amount of each system installed.

6.2.5 Final contract amount of each system installed, including all change orders and bulletins.

6.3 The installing contractor shall submit with the bid the names and registration numbers of members of the firm that have a valid membership and are certified with BICSI as Registered Communications Distribution Designers (RCDD). This Contractor shall identify at least one RCDD assigned to this project in the bid and must be an employee of that company.

2. Execution

1. Design validation

1.1 The bidding, shop drawing submittal, procurement of materials, the installation as-builts and record documents shall be reviewed and overseen by the RCDD(s) assigned to the project.

1.2 The Contractor's bid, shop drawing submittals, as-builts and record documents shall bear the valid seal of the RCDD(s) assigned to this project.

1.3 All calculations, shop drawings, testing, certification and as-built documents shall be directly supervised by the RCDD assigned to the project.

1.4 A sub-contractor must provide the general contractor a copy of the manufacturer's certification that the sub-contractor is currently certified to install, test and warranty the proposed system prior to a bid submittal. See Section 27110, 7.5A and section 27010, 1.16A. The owner reserves the right to have the non-certified sub-contractor removed from the job.

2. Installation of equipment

2.1 Install all equipment in strict accordance with all installation specifications set by the equipment manufacturer. Where such directions conflict with the drawings and specifications, report such conflicts to the Project manager & Construction teams for resolution.

3. Work performed by others

3.1 Electrical contractor shall install 4" sq. sheet steel wall boxes, minimum 1" trade size conduit (or as indicated on drawings) stubbed 12" above ceiling with 6" radius (or as required by

ANSI/TIA-569 C), with a 90-degree bend at top in the direction towards route destination, and plastic bushing for recessed locations.

3.2 Electrical contractor shall install 4" sq. cast boxes. Minimum 1" trade size conduit (or as indicated on drawings) stubbed up to 10' AFF (or as indicated on drawings), with 6" radius (or as required by ANSI/TIA-569 C) for surface mounted locations.

4. Demolition work

4.1 All demolition of existing telecommunications cable, equipment and materials shall be specified by C&IT and done by this contractor unless otherwise indicated. Include all items such as, but not limited to, cable, patch panels, devices, and wiring back to the source, called out on the drawings and as necessary whether such items are indicated on the drawings or not to meet NFPA requirements.

4.2 In general, demolition of old low voltage telecommunications cabling work is indicated on the drawings, however, the contractor shall visit the job site to determine the full extent and character of this work. All existing voice and data jacks demolished need to be documented. A room number, jack number, approximate location in the room and the telecommunication room where it is terminated needs to be identified. This information must be returned to C&IT IOPS Networking Engineering Group, project management & the plant manager. If a contractor cuts and or damages a live network cable by mistake it is the responsibility of the contractor to replace the cable to its original working condition as quickly as possible.

4.3 None of the recovered material shall be reused in the new work.

4.4 Where new walls and/or floors are installed which interfere with existing telecommunications outlets, devices, etc., this contractor shall adjust, extend and reconnect such items as required to maintain continuity of same.

4.5 All electrical work in altered and unaltered areas shall be run concealed wherever possible. Use of surface metal raceway or exposed conduits will be permitted only were approved by the architect/engineer and as specifically indicated on the drawings.

5. Work in existing buildings

5.1 Adequately protect and preserve all existing and newly installed work. Promptly repair any damage to same condition at this the contractor's expense.

5.2 Consult with the owner's Project Coordinator and C&IT Project Coordinator as to the methods of carrying on the work so as not to interfere with the owner's operation any more than absolutely necessary. Accordingly, all telecommunications services shall be kept in operation as long as possible, and the services shall only be interrupted at such time as will be designated by the owner's representative.

5.3 Where interruption of service cannot be avoided, C&IT must have prior notice no less than five (5) business days to assess impact and inform users of the work.

6. Coordination

6.1 If there is a general contractor, the general contractor is responsible for the construction schedule. All work activities are to be coordinated with the general contractor.

7. Chases and recesses

7.1 Chases and recesses shall be provided by the architectural trades, but the contractor shall be responsible for coordinating their accurate location and size.

8. Sleeves

8.1 Provide and install Hilti Speed Sleeve model CP-653-BA for riser system or EZ path fire stop system wherever conduits or cabling pass through fire rated walls, floors or cables pass through openings in walls.

8.2 Sleeves are used in standard walls and floors (non-riser) with no fire rating. All sleeves through the floor are to extend 4 inches above floor, unless otherwise noted. Provide escutcheons at each sleeve in finished areas and adequate spacing between sleeves to accommodate escutcheons. Specseal Ready sleeve system. (Part # STI FS100, STI FS200, or STI FS400) And must be installed to manufacturer specifications.

9. Access doors

9.1 Provide access doors for installation by architectural trades. In the walls, provide Milcor No. "DW" or "M" as required to make all controls, electrical boxes and other equipment installed by the Contractor accessible. Minimum size 12 inches x 12 inches. In the ceiling, provide Milcor No. 3210, 3105 or 3206 for accessibility as mentioned above, 24 inches x 24 inches minimum size. The plaster or acoustical tile insert shall be by the architectural trades. Areas with accessible ceilings (ceilings where tiles are not fastened in place and can be individually removed without removal of adjacent tiles) will not require access doors.

9.2 When access doors are in fire resistant wall or ceilings, they must bear the Underwriters Laboratories, Inc., Label, with time design rating equal to or exceeding that of the wall or ceiling unless they were a part of the tested assembly.

10. Cleaning

10.1 All debris shall be removed daily as required to maintain the work area in a neat, orderly condition.

10.2 Final cleanup shall include, but not be limited to, cleaning all telecommunications equipment spaces, devices, cover plates, and removing all scrap cable and debris from pathways.

11. Protection and handling of equipment and materials

11.1 Newly installed network equipment shall be protected from theft, dust or damage while construction is going on.

11.2 Protect conduit openings with temporary plugs or caps.

11.3 Locks must be installed on telecommunication room doors prior to any equipment installation.

12. Extra work

12.1 For any extra telecommunications work must be forwarded to the general contractor, an itemized breakdown of the estimated cost of the materials and labor required to complete this work. This contractor shall proceed only after receiving an impact report from the university establishing the agreed price and describing the work to be done. This doesn't amend the language of the main construction contract.

13. Drawings and measurements

13.1 Final as-built drawings must be delivered at project completion in CAD and BIM file formats.

13.2

14. Automation System Program Code

14.1 All automation system non-compiled and compiled program codes, source codes, custom modules, graphical user interface screen shots and any other automation system programming data and material (Program Code) shall be provided to the university in hard copy and on CD-ROM in an unencrypted form as acceptable to the university.

14.2 Copyright for the Program Code shall be assigned to the University for purposes of system maintenance.

14.3 Provision of and copyright assignment of the program code to the university by the vendor shall be conditions of the purchase order and contract acceptance by the vendor.

14.4 Provision of and copyright assignment of the program code to the university by the vendor shall be conditions of final system acceptance by the university.

END OF SECTION 27010

Section 27110 - Telecommunications interior pathways

1. General

1. References

- 1.1. ANSI/NFPA 70 - National Electrical Code
- 1.2. NFPA-297 - Guide on Principles and Practices for Communication Systems
- 1.3. ANSI/TIA 568-C - Commercial Building Telecommunications Cabling Standard
- 1.4. ANSI/TIA 569-C - Commercial Building Standard for Telecommunications Pathways and Spaces
- 1.5. ANSI JSTD- 607 B - Commercial Building Grounding and Bonding Requirements for Telecommunications
- 1.6. ANSI/IEEE-110-1992 - Powering and Grounding Sensitive Electronic Equipment
- 1.7. BICSI – Building Industry Consulting Services International

2. Submittals

- 2.1. Submit all structured cabling system raceways and supports identified in this section under provisions of Section 27010.
- 2.2. Product data: Provide for products specified and required.
- 2.3. Shop drawings: Indicate project specific part numbers, dimensions, support points, fittings and finishes.

3. Project record documents

- 3.1. Submit all structured cabling system raceways and supports identified in this section under provisions of Section 27010.
- 3.2. Accurately record equipment layout and cable layouts in all telecommunication spaces.

4. Delivery, storage, and handling

- 4.1. Deliver, store, protect, and handle products to site under provisions of section 27010.
- 4.2. Protect products from corrosion and entrance of debris by storing above grade.
- 4.3. Provide appropriate covering.

5. Project conditions

- 5.1. Verify that field measurements are as shown on drawings.
- 5.2. Verify routing and termination locations of conduits, and cable pathways prior to rough-in.

6. Installation of cable support systems

- 6.1. Telecommunications cabling systems pathways shall be installed in accordance with ANSI/TIA 569-C.
- 6.2. Intra-building backbone cabling shall be installed in conduit, cable tray or J-hook support system.
- 6.3. Horizontal cabling (cabling from the telecommunications room to the work area outlet) pathways shall consist of [conduit], [cable tray], [J-hooks], [under floor duct system], [raised access flooring system], [accessible ceiling space], [cellular flooring system] as indicated on drawings and as required.
- 6.4. Where the accessible ceiling systems [raised access flooring systems] are used as the primary pathway, cabling shall be installed [in main cable tray runs] as indicated on the drawings, with individual work area cables routed exposed [in conduit] and supported as specified herein.

2. Products

1. J-hooks

1.1. Manufacturers:

- 1.1.1. Erico-Caddy.
- 1.1.2. B-Line.

2. Horizontal cable routed exposed through ceiling space shall be supported from J-hooks.

- 2.1. J-hooks shall be a minimum of 5/8" wide and shall have a bearing surface that complies with required bend radii of the specified cables to be supported.

3. Inner duct

3.1. Install inner duct through conduits and sleeves for optical fiber cabling installations.

- 3.2. Description: UL listed, non-metallic, corrugated flexible conduit for use in plenum or riser installations as applicable. Provide each inner duct with one 1/4" W pull tape with a tensile rating of 900 lbs.

3. Execution

General

1. Where cables pass through fire rated walls, the contractor shall provide and install Hilti Speed Sleeve model CP-653 BA or EZ path fire stop system. This penetration sleeve must match the fire rating of the wall. The penetration shall be sized per ANSI/TIA-569-C.

2. Any other wall or floor penetrations that aren't fire rated use Specseal Ready sleeve system where applicable. (Part # STI FS100, STI FS200, or FS400), the contractor shall fire-stop the penetrations, after final cable installation, using engineer-approved materials. Fire-stopping materials shall be installed per manufacturer's recommendations and shall maintain partition rating and integrity. All fireproofing shall be applied in a neat manner with all excess material cleaned from all walls and surfaces. Contractor shall replace and re-install all fireproofing materials removed during cable installation.
 - 2.1. Contractor shall patch and repair any holes or other damage to walls or partitions and paint to match original, as applicable.
 - 2.2. The telecommunication cabling contractor shall provide plastic and/or grounding bushings, as applicable, on all conduit sleeves, stubs and conduit terminations that may have been missed by the electrical contractor.
 - 2.3. All cutting, patching and restoration to the original condition of walls, ceilings, floors, etc., shall be the responsibility of the contractor.
 - 2.4. All ceiling removal and restoration required for the execution of this work shall be the responsibility of the contractor.
 - 2.5. Any additional existing voice and data jacks demolished need to be documented. A room number, jack number, approximate location in the room and the telecommunication room where it is terminated needs to be identified. This information must be returned to C&IT project management, network engineering, & the plant manager.
 - 2.6. All cabling installed exposed in accessible ceiling systems shall be supported by cable tray or J-hooks.
 - 2.7. All J-hooks shall be supported directly from the structure above or wall mounted, as applicable, independent of ceiling framing, electrical conduit, mechanical piping and ductwork. Provide all-thread rod with ¼" diameter or equivalent supporting means with suitable fasteners when attaching to structure or structural members. Increase size of support as required when multiple J-hooks (stacked or tree configuration is used) are attached to single support based on maximum loading capacity of J-hooks.
 - 2.8. J-hooks shall be spaced 48" minimum or 60" maximum on center.
 - 2.9. Telecommunications cabling shall be routed in continuous conduit above hard ceilings or between floors in any kind of offset condition.
 - 2.10. Telecommunications cable pathway routing shall be coordinated with above ceiling work of other contractors to avoid conflicts and potential sources of EMI.
 - 2.11. Do not route exposed telecommunications pathway within 12" of lighting fixtures and electrical power feeders.
 - 2.12. Route inner duct for all fiber optic backbone cabling, in cable tray, conduit, and sleeves. Coordinate routings and quantities with drawings.

END OF SECTION 27110

Section 27130 - Communication equipment spaces support hardware

1. General

1. References

- 1.1. ANSI/NFPA 70 - National Electrical Code.
- 1.2. NFPA-75 - Protection of Electronic Computer Data Processing Equipment.
- 1.3. NFPA-297 - Guide on Principles and Practices for communication

2. Systems

- 2.1. ANSI/TIA 568-C - Commercial Building Telecommunications Cabling Standard.
- 2.2. ANSI/TIA 569-C - Commercial Building Standard for Telecommunications Pathways and Spaces.
- 2.3. ANSI/TIA 607-B - Commercial Building Grounding and Bonding Requirements for Telecommunications.
- 2.4. ANSI/IEEE-110-1992 - Powering and Grounding Sensitive Electronic Equipment.
- 2.5. BICSI – Building Industry Consulting Services International.

2. Products

1. Equipment racks

- 1.1. Manufacturers:
 - Chatsworth Products (CPI)
 - Homaco
 - Hubbell
- 1.2. Description: Nominal 19" x 84"H equipment rack, with universal EIA hole spacing for mounting equipment and accessories.
- 1.3. Material: 6061-T6 heavy-duty aluminum or equivalent.
- 1.4. Provide all hardware for floor mounting and anchoring.
- 1.5. Provide one (1) equipment shelf and all mounting hardware.

2. Power strips equipment racks

2.1. Manufacturers:

- APC – Model APC 8841
- Tripplite – Model PDUMNV30HV2

2.2. Provide one 208-volt, 30-amp, single phase power strip for each rack installed.

2.3. Install one 208-volt, 30-amp, single phase power strip on each equipment rack.

2.4. Mount vertical on side of rack.

2.5. No Velcro mounting allowed.

2.6. Plug mates with a L6-30 receptacle.

2.7. Install the power strip with a 6 to 10-foot cord.

2.8. Include a temperature and humidity Sensor.

2.9. Provide one 120-volt 20-amp dedicated power circuit for each equipment rack.

2.10. Provide one 120-volt 20-amp “metered” PDU for each 120-volt circuit.

2.11. Provide four additional 120-volt 20-amp service outlets, one on each wall of the Telecommunications room.

2.12. Use factory mounting hardware on the equipment rack whenever possible.

3. Vertical cable management

3.1. Manufacturers:

- Same as equipment rack.

3.2. Description:

3.2.1. Vertical duct style cable management panel for mounting on equipment racks with slotted construction to allow multiple cable exits, [double sided for front and rear management] and fluted to allow cables to pass from front to rear.

3.2.2. Removable solid cover.

3.2.3. Material: ASTM A569 steel or 5052-H32 aluminum.

- 3.2.4. Provide two 3" W cable management units between racks and one 6" W at ends. Cable management unit shall be [84"H] [96"H] by nominal 6" D
- 3.2.5. Finish: Electrostatic powder coat, post-fab painted in black.
- 3.2.6. Provide all hardware required for securely mounting panel to equipment rack.

4. Horizontal cable management

4.1. Manufacturers: Provide (1) per telecom rack installed

- Chatsworth
- Homaco

5. Equipment cabinets

5.1. Manufacturers:

- Chatsworth Products (CPI)
- Hubbell.
- Great Lakes Cabinets
- Hoffman.

5.2. Standard equipment cabinet, floor mounted, will be nominal 24" W x 30" D x 84" H, fully welded steel construction, lockable front and rear doors (roof fans) cable management, 19" EIA mounting racks and adjustable, fixed shelves as required.

5.3. The top cover shall accept the mounting of a 250 CFM cooling fan.

5.4. The cabinet shall be pre-configured for 19" mounting with universal hole spacing per the EIA 310 standard requirements.

5.5. The cabinet shall feature three sets of rails, front, center, and rear. The front set of rails shall be 20 rack positions high, from the bottom of the cabinet. The rear and center rails shall be the full internal height. The recess of all three sets of rails shall be adjustable forward and back. The rails shall be tapped for a #10-32 screw. The center rails shall be formed in a 'C' profile, 3" deep, tapped on both the front and rear flanges to provide the functionality of an open frame rack. The front and rear rails shall be of an L shape.

6. Wall-mounted equipment cabinets

6.1. Manufacturers:

- Chatsworth Products (CPI)
- Hubbell.
- Great Lakes Cabinets
- Hoffman.

- 6.2. Wall mount equipment cabinets shall only be installed where floor space for equipment racks is not available and must be approved by C&IT plant manager before installation is allowed.
- 6.3. Equipment cabinet, wall mounted will be nominal 24" W x 48" H x 24" D, with equivalent construction as standard floor mounted cabinet except with double hinged center section.
- 6.4. Load capacity of the cabinet shall be 150 lbs.
- 6.5. Provide dedicated 120V circuit installed in cabinet.

7. Backboards

- 7.1. AC-grade fire rated or better plywood backboard in sheets measuring 4' W x 8' H x 3/4"D. Plywood sheets shall be flat and free of all voids. Do not paint the plywood. This voids the fire rating.

8. Telecommunications cable runway

- 8.1. Manufacturers:
 - Chatsworth Products (CPI)
 - Homaco.
 - Hubbell.
 - Cablofil
 - Wire Basket Tray (WBT).
- 8.2. Description: 16-gauge tubular steel stringer style, with rungs 9"-12" O.C.
- 8.3. Material: 3/8" x 1-1/2" tubular steel with 1/2" x 1" steel channel rungs, or equivalent.
- 8.4. Width: 12" or 18" indicated on drawings.
- 8.5. Cable runway must be mounted from the sides. It is not permissible to support the cable runway from the center. No exception to this will be allowed.

3. Execution

1. Equipment racks

- 1.1. Contractor shall furnish and install wall mounted and floor-mounted equipment racks per manufacturer's recommendation.
- 1.2. The racks shall be labeled according to the drawings and in accordance with specification 27170 "Cable Plant Administration and Testing."
- 1.3. Free standing equipment racks shall be bolted to the floor using anchors in concrete floor and toggle bolts through raised flooring.

- 1.4. All racks, cabinets, armored cable, & cable transport hardware shall be bonded to the telecommunications system ground riser.
 - 1.5. Mount the top of two post equipment racks to the bottom of cable runway for equipment rack support strength and cable flow into equipment rack.
 - 1.6. All equipment racks and cable runway must be grounded and bonded per BICSI standards.
2. **Cable management**
- 2.1. Install vertical cable management panels per telecommunication room specifications.
 - 2.2. Install vertical panels on each side of free-standing equipment racks.
 - 2.3. Install (1) Horizontal cable management per rack.
3. **Backboards**
- 3.1. Three walls in the telecommunication rooms shall be covered with non-painted fire rated plywood backboards. A minimum 6" above finished floor to 8'-6" above floor (8 ft plywood).
 - 3.2. Normally, no plywood is needed on the wall where the door is.
4. **Telecommunications cable runway**
- 4.1. As a minimum, mount runway at each end to wall using appropriate hardware.
 - 4.2. Where overall length is greater than 10ft, provide supplemental support from structure above or from equipment racks and cabinets below.
 - 4.3. Mount runway directly to top of racks unless noted otherwise on drawings for the cable runway to be higher.
 - 4.4. Runway shall run around three sides of the perimeter in the telecommunications room and an additional fourth section across the center of the room securing the top of the equipment racks to the cable runway. Normally no cable runway will be needed on the door side wall unless cable sleeves / cable tray entering the telecommunication room are over the door header or noted otherwise on the drawings.

END OF SECTION 27130

Section 27150 - Telecommunications cabling

1. General

1. References

- 1.1. ANSI/TIA-568-C - Commercial Building Telecommunications Cabling Standard.
- 1.2. ANSI/NFPA 70 - National Electrical Code.
- 1.3. FCC Part 68 - Connection of Terminal Equipment to the Telephone Network.
- 1.4. FCC Part 15 - Radiation Limits
- 1.5. FCC Part 76 - Cable Television Service.
- 1.6. BICSI TDMM - Telecommunications Distribution Methods Manual, Latest Edition.
- 1.7. BICSI TCIM - Telecommunications Cabling Installation Manual, Latest Edition.

2. Project conditions

- 2.1. Verify field measurements are as shown on drawings.
- 2.2. Verify suitability of all pathways prior to cable installation.

3. Cabling system performance

3.1. General:

- 3.1.1. Cabling system performance shall meet or exceed current industry standards and/or manufacturers' specifications as specified herein.
- 3.1.2. The cable installed in the walls, connectors, jack, patch panels, and patch cords must be the same manufacture and model that forms the complete cabling system channel. The total system shall meet the performance criteria described below.
- 3.1.3. The cable and connector devices shall be certified compatible by the manufacturer of each component to meet the performance criteria described below. Submit manufacturer's certification with submittals.
- 3.1.4. The referenced standards describing the performance below shall include all revisions, clarifications, and bulletins to the original standard referenced as well as any standards cross-referenced.
- 3.1.5. The referenced standards describing the performance below shall apply to backbone cable, horizontal cabling, and connecting hardware performance

requirements as well as installation standards and techniques and field testing and verification of performance.

- 3.1.6. A plenum category 5 (CAT5E) cabling in a 25 pair cable bundle is to be utilized for voice (Analog Gateway connected telephone) building backbone riser only. Category 5 performance is defined by ANSI/TIA 568-C for 100-ohm UTP cables and associated connecting hardware whose transmission characteristics are specified up to 100 MHz.
- 3.1.7. Category 6 enhanced (CAT6E) cabling shall be utilized for all voice, data, wireless access points and security camera horizontal wiring. For WSU projects, any one of the following five cat6e structured cabling system products are acceptable:
 - Hubbell NEXTSPEED Cat 6 enhanced
 - Superior-Essex NextGain Cat6EX
 - Leviton-BerkTek Lanmark-2000
 - Belden Cat6+ Premium 3613
 - CommScope Uniprise CS37P Cat6E
- 3.1.7.1. Category 6e performance is defined by the manufacturers of the above cabling products.
- 3.1.7.2. All cable installed, patch cords, jacks and patch panels must be same manufacturer and product series and or certified compatible by the manufacturer.
- 3.1.8. Fiber optic cabling shall be utilized for all data building backbone riser. Fiber optic performance is defined as follows:
 - 3.1.8.1. Multimode: 50/125µm laser optimized fiber optic cable. The cable shall be dual rated for 850nm and 1300nm and meet all performance requirements of TIA/EIA 568-492aaac (om3) at each transmission wavelength.
 - Maximum attenuation:
 - 3.5dB/km @ 850nm
 - 1.5dB/km @ 1300nm
 - Bandwidth:
 - 1500 MHz*km @ 850nm
 - 500 MHz*km @ 1300nm
 - 3.1.8.2. Single mode: Provide nominal 9/125µm core/cladding, single mode SMF28e or equivalent fiber optic cable. Use G.652 type cable for any repair or maintenance. The cable shall be rated for 1310nm and 1550nm and meet all performance requirements of ANSI/TIA 568-C at each transmission wavelength.
 - Maximum Attenuation:
 - 0.5dB/km @ 1310nm
 - 0.5dB/km @ 1550nm
 - Bandwidth:
 - 2GHz*km @ 1310nm
 - 2GHz*/km @ 1550nm

- 1.1.1. Typical fiber cable is SMF28e or equivalent. Use G.652 type cable for any repair or maintenance.

3.2. Contractor qualifications

- 3.2.1. The installing contractor shall be certified by the cabling and connector manufacturer of the structured cabling system product selected. A letter of certification from the manufacturer for the individuals working on the project must be included with the bid submittal. No exception to this will be allowed.

3.3. Submittals

3.3.1. Product Data Sheets

- 3.3.1.1. Submittals can be sent electronically to WSU project managers.
- 3.3.1.2. The binders shall contain manufacturer's product data sheets for the specific items to be installed for this project.
- 3.3.1.3. The Contractor shall indicate specific color, style, configuration, etc., and all accessories specified and required for a complete installation.

3.4. Unit pricing

- 3.4.1. Provide separate unit pricing included with bid for each of the following:
 - 3.4.1.1. A complete workstation drop of each type of outlet indicated (e.g., A, B, C, etc.) of length 100 feet, including all cabling, connectors, faceplate, labeling, installation, termination, and testing.
 - 3.4.1.2. Complete schedule C of WSU's purchasing bid package.

3.5. UTP cabling system warranty

3.5.1. General

- 3.5.1.1. The UTP voice and data cabling system is warranted by the manufacturer(s) "Application Warranty" of the components for a period of not less than 20 years from the time the installation is deemed complete, provided certified installation and testing is followed.
- 3.5.1.2. It shall be the sole responsibility of the low voltage cabling Contractor to register the project with the manufacturer(s) and meet all manufacturers' "Application Warranty" requirements.
- 3.5.1.3. It shall be the sole responsibility of the low voltage cabling Contractor to provide Owner with test results, all manufacturers' warranty certificates with Record Documents including a site plan elevation with outside plant manholes, hand holes and conduit pathways.

3.6. Warranty Coverage

- 3.6.1. Product - all passive components of the cabling system shall be warranted to be free from defects in material and workmanship for the entire duration of the warranty.
- 3.6.2. Paint or any other material on the UTP cable voids the warranty. If this can't be removed during the installation, the effected cables will need to be replaced.
- 3.6.3. Any UTP CAT6 cable or component that has been painted and / or not satisfactorily passing tests or failing to meet quality installation standards as described in the standards will be repaired or replaced as directed by C&IT Network Engineering Group at the contractor's expense.

3.7. Warranty Requirements

- 3.7.1. Provide a channel warranty for all data drops.
 - 3.7.2. Warranty shall cover repair or replacement of all defective components free of charge, including all labor performed by a manufacturer-certified installer. All new or replacement components shall be furnished new. Never used, reused, reconditioned, or refurbished components are allowed by the manufacture.
- 3.8. The installing contractor must be certified by the cabling and connector manufacturers as an approved and trained installer of their equipment & product.

2. Products

2. Inter-building fiber optic backbone

2.1. Single mode fiber optic cabling

2.1.1. Manufacturers:

- Systemax
- Corning
- BerkTek
- CommScope
- Belden

2.2. Description:

- 2.2.1. Nominal 9/125 μm , [6] [12] [18] [24] [36] [48] [96] strand or as indicated on drawings, loose tube, all-dielectric cable, rated **for outdoor use**. Cable shall have water-blocking properties to prevent water penetration and fiber damage. Cable shall have maximum 12 stands per tube, and an overall Polyethylene jacket.
- 2.2.2. Nominal 9/125 μm , [6] [12] [18] [24] [36] [48] [96] strand or as indicated on drawings, loose tube, OFNR rated **for indoor/outdoor use**. Cable shall have water-blocking properties to prevent water penetration and fiber damage. Cable shall have maximum 12 stands per tube, and an overall UV resistant, flame-retardant jacket.

3. Intra-building copper backbone (voice only)

3.1. Manufacturers:

- Superior-Essex
- BerkTek
- Belden
- Hubbell
- CommScope

3.2. Description:

- 3.2.1. Twisted pair copper conductors, 24 AWG, solid annealed copper.
- 3.2.2. Provide [25] [50] [100] pair cable bundles, as indicated on Drawings.
- 3.2.3. Cable rated CAT5E voice backbone cable, UL Listed CMR, CMP as required.
- 3.2.4. 25 pair binder groups color coded per industry standards.
- 3.2.5. Flame-retardant PVC insulation for riser rated applications, low- smoke PVC insulation for plenum applications, color-coded for each conductor per industry standards.
- 3.2.6. White, flame-retardant PVC outer jacket for riser rated applications, gray low-smoke PVC outer jacket for plenum applications.

4. Intra-building fiber optic backbone

4.1. Multimode fiber optic cabling

4.1.1. Manufacturers:

- Systemax
- Corning
- BerkTek
- CommScope
- Belden

4.1.2. Description: 50/125 μm , [6] [12] [18] [24] [36] [48] strand or as indicated on Drawings, tight buffered, OFNP. Cable shall be comprised of individually jacketed, and uniquely identified fibers with an overall blue sheath.

4.1.3. Horizontal and Vertical fiber cable shall be furnished with performance requirements for the system served (voice, video or data) as indicated on the drawings riser diagram.

4.2. Single mode fiber optic cabling

4.2.1. Manufacturers:

- Systemax
- Corning
- BerkTek
- CommScope
- Belden

4.2.2. Description: Nominal 9/125 μm , [6] [12] [18] [24] [36] [48] strand or as indicated on Drawings, tight buffered, OFNP. Cable shall be comprised of individually jacketed, and uniquely identified fibers with an overall yellow sheath.

4.2.3. Horizontal and Vertical fiber cable shall be furnished with performance requirements for the system served (voice, video or data) as indicated on the drawings riser diagram.

5. Copper horizontal cabling (See Cabling System Performance)

5.1. Manufacturers:

- CommScope
- BerkTek
- Superior-Essex
- Hubbell
- Belden

5.2. Description:

- 5.2.1. Horizontal cable shall be furnished with performance requirements for the system served (voice, video or data) as indicated on the drawings riser diagram.
- 5.2.2. Category 6 enhanced: 23 AWG, 4-pair, 100 ohms, UTP, [CMR] [CMP], with green jacket for data and wireless access points, yellow jacket for voice cabling, purple jacket for security camera cabling, and blue jacket for Building Automation Systems (BAS). See exact products in section Cabling System Performance above.
- 5.2.3. Workstation, server, printer, BAS etc. data jacks will terminate in their own group of patch panels. Wireless access point and security camera data jacks will terminate on their own separate group of patch panels. All patch panels are installed in the equipment racks. No wall mounted patch panels allowed without authorization from C&IT.

6. UTP jacks and connectors

6.1. Manufacturers: (use corresponding jacks based on cable type installed)

- CommScope UNJ600.

- Leviton
- Hubbell
- Belden

7. Modular jacks for UTP cables:

- 7.1. 8 position, 8 conductor, non-keyed, universal modular jack, snap-in type, terminated with a 110-style pc board connector, color coded for T568A and T568B wiring.
- 7.2. Designed to terminate 22-26 AWG solid on insulation-displacement.
- 7.3. 110-style connectors.
- 7.4. Contacts shall be minimum 50 micron gold-plated in the contact area.
- 7.5. Rated to match the performance of the cabling system they are installed on.
- 7.6. Color coded for system served as indicated on the Drawings.
- 7.7. Furnish keystones (icons) for jack identification. Keystones for voice, data, wireless access points and security cameras jacks shall be [orange].
- 7.8. When installing outdoor cameras, APs, or any type of network device, you must use one of the following Hi-Impact jacks and patch cords.
- 7.8.1. Manufacturers:
- CommScope UMP610-24P or UMP610-48P.

 - Leviton
 - Hubbell HI6Coupler and Jack. HI603AE Patch Cord
 - Belden

7.9. When installing outdoor cameras, APs or any type of network device, you must use one of the following CAT6E POE compatible lightning surge protection devices as part of the telecommunication room termination mounted to the backboard:

7.9.1. Manufacturers:

- AT-2210 ATLAN Cat6 POE
- Phoenix Contact DT-LAN CAT.6+ 2281007 (DIN Rail Mounted)
- L-Com HGLN-CAT6JT

8. UTP patch panels

8.1. Manufacturers:

- CommScope UNP-6-DM-1U-24 or UNP-6-DM-2U-48.

- Leviton
- Hubbell
- Belden

8.2. UTP patch panel

- 8.2.1. Patch panel shall serve as data jack, voice jack, security camera and wireless access point system horizontal cross connect.
- 8.2.2. Wireless access point and security camera data jacks will be terminated on their own patch panel separate from the workstation data jack patch panels.
- 8.2.3. Patch panel shall be configured for standard 19" rack mounting.
- 8.2.4. High density type with snap in 24 modular jack ports for every standard rack mount unit (1.75" high).
- 8.2.5. Maximum 6 port groupings of replaceable modules.
- 8.2.6. Terminations for the "building side" cabling on 110-style insulation PC board connectors color-coded for T568B terminations.
- 8.2.7. Horizontal and vertical cable management hardware front and rear.
- 8.2.8. Performance shall meet the performance of the cabling system they are installed on.
- 8.2.9. Constructed of black anodized aluminum with adequate structural integrity so that panel will not deflect when center of panel is pushed with the hand.
- 8.2.10. Provisions for icons and labeling to comply with the labeling requirements in specification 27170, "Cable Plant Administration and Testing".

9. Cross-connect blocks

9.1. Manufacturers:

- CommScope.

- Leviton
- Hubbell
- Belden

9.2. Cross-connect blocks

- 9.2.1. Cross connect blocks shall be used for voice connectivity [backbone to] horizontal cross connects:
- 9.2.2. Wall-mount 110-type wiring blocks mounted in a modular frame if needed.

10. Face plates

- 10.1.Manufacturers: Same as jacks and connectors, unless otherwise noted. In almost all cases in labs, stainless steel plates will be called out in lieu of plastic. Reference construction drawings.
- 10.2.Face plates for wall mounted workstation outlets shall allow a minimum 2 and maximum of 6 positions and accept snap-in jacks, as specified.

11. UTP patch cords

11.1.Manufacturers

- 11.1.1. Shall be the same manufacturer and type as the cable, jacks and patch panels installed in the building.

11.2. Description

- 11.2.1. Provide one (1) 1' patch cord for each data port installed in the patch panel.
- 11.2.2. Provide one (1) 10' patch cord for each data port installed at the workstation area.
- 11.2.3. For the workstation room side provide patch cords with stranded conductors and jacketing for greater flexibility.
- 11.2.4. Patch cords shall be gray color for the workstation, and telecommunication room areas. Patch cords shall be grey color for the access point. Patch cords shall be purple color for the security cameras. Patch cords shall be blue for BAS.
- 11.2.5. Coordinate possible different lengths with C&IT prior to placing order. Project or scope change could require different lengths then on the original submittals.

12. Fiber optic connectors for both inter–building and intra–building cables

12.1. Manufacturers:

- Corning Cable Systems.

12.2. Multimode fiber optic connectors shall be:

- 12.2.1. Field installed [LC/UPC] type in 12/24 port panels for INTRA – BUILDING riser tie cabling 12 strands minimum between all IDFs To MDF rooms. Provide [black] color connector & bulkhead.

12.2.2. WSU does not install Multimode fiber cabling between buildings.

- 12.2.3. Data rates have exceeded the ability to use between building Multimode.

12.3. Single-mode fiber optic connectors shall be:

- 12.3.1. Field installed [LC/UPC] type in 12/24 port panels for INTRA – BUILDING riser tie cabling 12 strands minimum between all IDFs To MDF rooms. Provide [Blue] color connector & bulkhead.
- 12.3.2. Field installed [LC/UPC] type in 48/72/96 port panels for INTER – BUILDING tie cabling 48 strands minimum between hub & Endpoint buildings. Field installed [LC/UPC] type in 96/144 port panels for INTER – BUILDING tie cabling 96 strands minimum between hub & hub buildings. Provide [blue] color connector & bulkhead.

12.4. Single-mode fiber optic connectors for video shall be:

- 12.4.1. Field installed [LC/APC] type connectors on the last two port panels for INTER– BUILDING riser tie cabling between telecommunication rooms. Provide [green] color connector & bulkhead.

- 12.4.2. Field installed [LC/APC] type connectors on the last two port panels for INTER – BUILDING tie cabling between buildings. Provide [green] color connector & bulkhead.
- 12.5.
- 12.6. Connectors shall be fusion type pigtails. Compression type connectors are not permitted.
- 12.7.
- 12.8. Existing & project installed fiber optic cabling must maintain a minimum of 2 unused strands.

13. Fiber optic patch panels / LIU

- 13.1. Manufacturers:
 - CommScope.
 - Corning
 - Leviton
- 13.2. Description
 - 13.2.1. Rack-mounted, minimum 12-port Maximum 96-port patch panel with modules or panels.
 - 13.2.2. Use factory terminated fusion splice LC pigtail type connectors.

3. Execution

1. General

- 1.1. In addition to the notes contained on the Drawings, the following Contractor notes shall apply.

2. Cable routing

- 2.1. Route all cables and cable raceways parallel to or perpendicular to building structure.
- 2.2. All cables shall be installed as single continuous "homerun" pulls from connector block to connector block, or from patch panel in the telecommunications room to the data workstation outlet in the work area.
- 2.3. Cable that is installed above a suspended ceiling must be supported per NFPA code requirements. Three choices are, conduits, cable tray or by J-hooks.
- 2.4. No tie-raps or bundling allowed.
- 2.5. The maximum spacing of cable hangers, supports and the number of data cables per hanger shall not exceed BICSI specification.
- 2.6. The installation contractor shall be responsible to replace all fire-proofing materials required for the installation. Any missing fire-proofing materials shall be reported to WSU for repair to maintain required fire rating of structure.
- 2.7. Telecommunication cable and infrastructure shall be independently supported.
- 2.8. Do not support or tie-wrap any cables to ductwork, plumbing lines, fire suppression, electrical conduits, telecommunication conduits, mechanical systems, or ceiling system.
- 2.9. Do not route cables through a block wall without a proper sleeve, directly lay data cables on ductwork, piping and plumbing systems or on top of the lay-in ceiling tile.
- 2.10. All cable must be free of tension at both ends as well as over the length of the run.

- 2.11. Only Velcro straps are permitted as cable bundle supports. Waterfalls from cable tray shall not pinch, bind, crimp or in any way deform or cause physical damage to the cable jacket or alter the electrical characteristics of the data cables.
- 2.12. Contractor shall take care to assure that during and upon completion of the installation, all cables are free of kinks, sharp bends, twists, gouges, cuts or any other physical damage which may cause physical or electrical characteristic alterations to the cables. The cables must also be installed at the proper room temperature. Any of these conditions will constitute a replacement of the installed cable.
- 2.13. Contractor to observe all minimum bend radius and tension limitations, etc., as specified by the cable manufacturer when installing the cables.
- 2.14. Contractor shall supply neatly bundled slack loops of length 10 feet for all cabling in telecommunications spaces. Provide neatly bundled slack loop 1 foot above the ceiling at workstation end.
- 2.15. Provide Velcro cable ties periodically in all runs and within the telecommunications spaces. Provide slack loops per BICSI standards.
- 2.16. Route all optical fiber cabling in inner duct. Armored fiber cable doesn't need to be in innerduct. Support inner duct with j-hooks a maximum five feet on center when not routed in conduit or cable tray.

3. Cable terminations

- 3.1. The certified contractor who installs the telecommunications cabling must be the one who terminates the telecommunications cabling and tests the finished data link / channel. It is not allowed to have a non-certified electrical contractor install the telecommunications cable and have another certified contractor terminate, test and warranty the product. No exceptions to this will be allowed. Terminate all wiring at both ends using the T568B convention. All voice and data cables shall be terminated in accordance with ANSI/TIA 568-C installation guidelines.
- 3.2. Terminate all wiring at both ends using the T568B convention. All voice and data cables shall be terminated in accordance with ANSI/TIA 568-C installation guidelines.
- 3.3. All data cables shall be terminated on rack mounted, high density, patch panels.
- 3.4. Wireless access points, security cameras and all other "internet of things" data jacks will be terminated on their own patch panel separate from the workstation data jack patch panels.
- 3.5. All data jacks above ceiling must be orange, securely mounted and labeled. No free floating or double stick mounted jacks are allowed.
- 3.6. All cable terminations shall be free of stress or tension when complete.

4. Outlets

- 4.1. Data jacks are installed in outlet boxes on the wall, approved raceways or directly wired and mounted cubical furniture.

5. Face plates

- 5.1. Contractor shall provide standard faceplate with blank inserts for all outlets indicated as "future".

6. Patch panels

- 6.1. Mount patch panel according to equipment rack elevations.

7. **Voice riser connecting blocks**

- 7.1. If needed, mount 110 style-connecting blocks on plywood backboard.
- 7.2. Provide “D rings” and cable management between blocks.

END OF SECTION 27150

Section 27170 - Cable plant administration and testing

1. General

1. References

- 1.1. ANSI/NFPA 70 - National Electrical Code.
- 1.2. NFPA-297 - Guide on Principles and Practices for Communication Systems.
- 1.3. ANSI/TIA 568-C - Commercial Building Telecommunications Cabling Standard
- 1.4. ANSI/TIA 569-C - Commercial Building Standard for Telecommunications Pathways and Spaces.
- 1.5. ANSI/ JSTD 607-B - Commercial Building Grounding and Bonding Requirements for Telecommunications.
- 1.6. ANSI/IEEE-110-1992 - Powering and Grounding Sensitive Electronic Equipment. G. BICSI – Building Industry Consulting Services International.

2. Products

1. Labels

- 1.1. Manufacturers:
 - Brady.
 - Brother P-Touch.
 - Equivalent by Tester manufacturer.
 - Equivalent by UTP connectivity manufacturer.

2. Description

- 2.1. Machine-printed permanent glossy polyester labels for racks, cabinets, faceplates, and panels. (Brady B-422).

3. Machine-printed, self-laminating vinyl for cabling and patch cords. (Brady B-427)

3. Execution

1. Labeling

- 1.1. Contractor to install all faceplate and equipment labels in accordance with manufacturer's recommendations and the specifications. All labels shall be neatly installed and shall be level with the floor and properly aligned on the faceplate.
- 1.2. All pieces of voice and data equipment, including wires, cables, fibers and their respective terminations shall be labeled and identified in accordance with ANSI/TIA 606-B.
- 1.3. Labels shall meet the requirements of UL 969 as outlined in the ANSI/TIA 606-B.
- 1.4. All horizontal and backbone subsystem copper and fiber cables shall be labeled at each end. Labeling is required at intermediate points such as pull boxes and consolidation points (where appropriate).

- 1.5. Do not install labels closer than 3" to the termination point.
- 1.6. Patch panel labels shall be printed with the associated user data jack number.
- 1.7. Contractor shall submit a sample of patch panel label strips to the Network Engineer for approval prior to installation.
- 1.8. Numbering schemes for fiber panels, copper patch panels and voice wall 110 punch blocks will go in ascending order.
- 1.9. Intra-building fiber riser cable labeling scheme is for building riser cables between telecommunication rooms, [cable type] - [WSU Building Number] - [floor number] - [telecommunication room number] [Fiber Type & Count]. Example: BRC-027.03.IDF315-SM48
- 1.10. Voice and data jack labeling scheme is [Room Number] – [jack number + function]. Ex: 222-V01, 222-D01, 222-V02, 222-D02, 223-V01, 223-D01, etc.
- 1.11. Access Control and One Card Data Labels must begin with AC. (Ex: AC-201-D01)
- 1.12. Audio Visual (A/V) Data Labels must begin with A/V. (Ex: A/V-201-D01)
- 1.13. Labeling shall be consistent at each end of cabling and at workstation outlet and patch panel or connecting block. Data jacks shall be orange located in the outlet bottom position (vertical) or the outlet right position (horizontal). Voice jacks shall be White located in the outlet top position (vertical) or the outlet left position (horizontal). All voice terminates in their own patch panel.
- 1.14. Wireless access point jacks labeling scheme is [WAP] - [Room Number]. If the access point is in a corridor, use the closest room number. Labeling shall be consistent at each end of cabling and at WAP outlet and patch panel or connecting block. When a wireless access point is located above the ceiling a label must be placed on the ceiling grid which contains a small red dot and the wireless access point jack number.
- 1.15. Security camera jacks labeling scheme is [CAM] - [Last 2 octets of the IP Number]. Elevated cameras must have labeling at the bottom which allows for viewing from ground level. Labeling shall be consistent at each end of cabling and at WAP outlet and patch panel or connecting block.
- 1.16. All access point and security camera jacks will be terminated together on their own patch panel separate from the workstation data patch panels.
- 1.17. Outdoor fiber cables must be labeled with WSU fiber ownership cable label and unique building or backbone fiber cable name. Fiber cable must be WSU tagged and have building number, count, & type in all manholes and hand holes with waterproof type labels.
- 1.18. All labels must be based on the final room numbers. Verify room numbering with Owner prior to installation of labels. Do not use room numbers that appear on construction drawings.

2. UTP system testing

- 2.1. Upon completion of the cable installation, the Contractor shall perform complete copper cable certification tests, according to all manufacturer's requirements for application warranty, testing required by TIA/EIA, including, but not limited to:
 - 2.1.1. Continuity checks on each cable, checking for opens and shorts.
 - 2.1.2. Cable length (Channel and Permanent Link).
 - 2.1.3. Correct pair polarity.
 - 2.1.4. Correct cable labeling at both ends.
- 2.2. Tests shall be performed with connectors installed.
- 2.3. Any UTP CAT6 cable or component that has been painted and / or not satisfactorily passing tests or failing to meet quality installation standards as described in the

- specification, shall be repaired and/or replaced as directed by C&IT Network Engineer at the Contractor's expense.
- 2.4. The Contractor shall prepare complete cable test reports for all installed cables for review and acceptance by WSU C&IT Network Engineering prior to acceptance and / or use of the cabling system.
 - 2.5. Category 6E UTP cable patch cords shall be manufactured, fully tested and verified in accordance with product specifications. No field made patch cords allowed.
 - 2.6. All cable testing shall be conducted by a certified technician using a Level III minimum Fluke Networks DSX 8000, or C&IT Network Engineering approved equivalent certification tester.
 - 2.7. The cable tester calibration must be up to date. Test results must have the operator with company name, WSU building project name and cable type field. The cable type field identifies the cable product type installed and tested.
 - 2.8. The test results must be submitted in one file / PDF format to C&IT for approval.
 - 2.9. The Category 6E Horizontal Cable Certification reports shall have complete testing of channel for voice and data drops, at frequency increments up to 450MHz and set the cable length limit to 295' as indicated in ANSI/TIA-568-C and test results will show the following:
 - 2.9.1. Cable ID Number which matches faceplate numbers and patch panel numbers
 - 2.9.2. Tester Calibration Validation Date. Must be calibrated every year.
 - 2.9.3. Building Project Name, Test Date, operator and company names.
 - 2.9.4. Cable Length
 - 2.9.5. Wire-Map
 - 2.9.6. Network Tests for 100BASE-TX and 1000BASE-T
 - 2.9.7. Attenuation
 - 2.9.8. Near End CrossTalk (NEXT)
 - 2.9.9. Power-sum NEXT (PS-NEXT)
 - 2.9.10. Attenuation to Cross Talk Ratio (ACR)
 - 2.9.11. Power-sum Attenuation to Cross Talk Ratio (PS-ACR)
 - 2.9.12. Equal Level Far End CrossTalk (ELFEXT)
 - 2.9.13. Power-sum Equal Level Far End CrossTalk (PS-ELFEXT)
 - 2.9.14. Return Loss
 - 2.9.15. Propagation Delay
 - 2.9.16. Delay Skew
 - 2.9.17. Signal to Noise Ratio
 - 2.10. Upon completion, before final payment the following must be provided:
 - 2.10.1. Provide (1) electronic copy of test results in PDF file format.
 - 2.10.2. Provide the manufacture warranty certificate upon completion.
 - 2.10.3. Test date.
 - 2.10.4. Tester make, model and calibration date.
 - 2.10.5. No exception to this will be allowed.
 - 2.11. After the horizontal cable tests have been performed, the Contractor shall install the faceplate labels and modular jack dust covers.

3. Optical fiber system testing

- 3.1. Upon completion of the fiber cable installation, the Contractor shall perform complete fiber cable certification tests, according to all manufacturer's requirements for warranty and all testing required by ANSI/TIA 568-C.
- 3.2. Test all fiber (100%) using a power meter using the encircled flux testing criteria as stated in the TIA TSB-4979 specification or TIA 526-14-B standard, testing all cables in both directions.
- 3.3. Provide test report and include as a minimum the following information for all cables:
 - 3.3.1. Fiber cable number
 - 3.3.2. Fiber length.
 - 3.3.3. Attenuation (loss in dB).
 - 3.3.4. Test date
 - 3.3.5. Tester make and model no.
 - 3.3.6. Tester calibration date.

END OF SECTION 271

Section 27600 – C&IT digital signage specifications

1. All Digital Signage installations shall comply with the latest version of the **WSU Standards for Telecommunications Infrastructure**
2. **Changes and Substitutions**
 - 2.1. Any proposed changes, deviations or substitutions of items, materials or methods specified below must be approved in advance by an authorized representative of WSU Computing & Information Technology (C&IT).
 - 2.2. Any items, materials or methods proposed as equivalent must be approved in advance by C&IT.
3. **Display**
 - 3.1. Make and Model
 - 3.1.1. [NEC P554 Flat Panel Display](#).
 - 3.1.1.1. Smaller NEC P-series displays may be used if space limitations exist.
 - 3.1.1.2. Provide minimum of 3-year depot warranty on display.
4. **Display Mount**
 - 4.1. Make and Model
 - 4.1.1. Chief Manufacturing LSA1U Fusion Fixed Wall Display Mount or equivalent.
 - 4.2. Wall reinforcement
 - 4.2.1. Securely anchor wall mount to existing studs/framing.
 - 4.2.2. Reinforce wall with 5/8" plywood back board if required.
 - 4.2.3. Field conditions shall determine mounting reinforcement requirements.
 - 4.3. Ventilation and installation clearance (recess mounting)
 - 4.3.1. Provide 3 inches clearance around perimeter of display for convection cooling and mounting access with recess-mounted displays.
5. **Player**
 - 5.1. Make and Model: Dell Optiplex 7090 Micro Digital Signage Player
 - 5.1.1. WSU Specifications
 - 5.1.1.1. I7 Processor
 - 5.1.1.2. INTEL-vPro
 - 5.1.1.3. 8 GB RAM
 - 5.1.1.4. 128 GB SSD storage
 - 5.1.1.5. DisplayPort to DisplayPort or DisplayPort to HDMI Cable
 - 5.1.1.6. Dual VESA Mount (Optional)
 - 5.1.1.7. 5 Year Basic Warranty
 - 5.1.1.8. No Microsoft Office
 - 5.1.2. Player Operating System
 - 5.1.2.1. Player must be provided with an installed, licensed version of Microsoft Windows 10 Enterprise 64 bit.
 - 5.1.2.2. Microsoft Windows Embedded (any version) is **not allowed**.

6. Audio/Video Transport

- 6.1. Transmitter
 - 6.1.1. Make: Extron Electronics
 - 6.1.2. Model: DTP HDMI 4K 330 Tx HDMI Tx - 330 feet (100 m max run length)
 - 6.1.2.1. P/N 60-1331-12
 - 6.1.3. Transmitters to be mounted on shelf in MDF/IDF IT Closet.
- 6.2. Receiver
 - 6.2.1. Make: Extron Electronics
 - 6.2.2. Model: DTP HDMI 4K 330 Rx HDMI Rx - 330 feet (100 m max run length)
 - 6.2.2.1. P/N 60-1331-13
 - 6.2.3. Receivers to be securely mounted behind flat panel display.
 - 6.2.4. Receiver may be remote powered from Transmitter or locally powered using power supply and 120 VAC.
- 6.3. Cable
 - 6.3.1. Make: Extron Electronics
 - 6.3.1.1. P/N 22-235-03 XTP DTP 24P Plenum
 - 6.3.2. Cable runs not to exceed 100 meters end-to-end.
 - 6.3.3. All cable shall be plenum-rated.
 - 6.3.4. All connectors shall be shielded and installed per Extron specifications.
 - 6.3.5. Cable shall support full bandwidth and full resolution 1080P, 1080i and 720p HDMI transport.
- 6.4. Jumper cables – Digital Signage Player to HDMI Transmitter
 - 6.4.1. HDMI Micro to HDMI
- 6.5. Jumper cables – HDMI receiver to display
 - 6.5.1. HDMI to HDMI

7. Labeling

- 7.1. All players, transmitters, receivers and cables shall be clearly labeled with the following information:
 - 7.1.1. Flat panel display locations.
 - 7.1.2. Display ID numbers.

8. Infrastructure

- 8.1. Cable A/V (HDMI Transport)
 - 8.1.1. Provide separate J-box and outlet for AV cabling located behind the display.
 - 8.1.1.1. Field coordinate exact location.
 - 8.1.2. Make: Extron Electronics
 - 8.1.2.1. P/N 22-235-03 XTP DTP 24P Plenum
 - 8.1.3. Cable runs not to exceed 100 meters end-to-end.
 - 8.1.4. All cable shall be plenum-rated.
 - 8.1.5. All cable shall be Shielded Twisted Pair (STP).
 - 8.1.6. All connectors shall be STP-compliant.
 - 8.1.7. All connectors shall be shielded and installed per Extron specifications.
- 8.2. Power
 - 8.2.1. Provide duplex 120 VAC, 20 ampere power outlets behind display.
 - 8.2.2. Provide dedicated 120 VAC 20 Amp circuit.
 - 8.2.3. The dedicated circuit shall not be connected to other utility or corridor circuits that may be used by others.

- 8.2.4. Field coordinate exact location.
- 8.3. Data
 - 8.3.1. Provide single data jack behind display per WSU Standards for Telecommunication Infrastructure.
 - 8.3.2. Field coordinate exact location.

9. MDF/IDF Requirements

- 9.1. Rack mounting of players
 - 9.1.1. Players and transmitters to be securely rack-mounted on shelf in nearest MDF/IDF IT Closet.
 - 9.1.2. Players shall be mounted in a manner that will not obstruct chassis cooling fans, air flow or convection cooling.
 - 9.1.3. Mount shelf in existing space in MDF/IDF relay rack.
 - 9.1.4. Field coordinate mounting with other rack mounted IT equipment.
 - 9.1.5. Provide generic 19-inch EIA mounting shelf as required.
- 9.2. Power
 - 9.2.1. Players require 120 VAC outlets, per player.

10. Interior Design Requirements

- 10.1. Coordinate interior design with Architect
 - 10.1.1. Recess mounting
 - 10.1.1.1. Coordinate design in advance with C&IT.
 - 10.1.1.2. Shop drawings must be approved in advance by C&IT.
 - 10.1.2. Millwork and cabinetry
 - 10.1.2.1. Coordinate design in advance with C&IT.
 - 10.1.2.2. Shop drawings must be approved in advance by C&IT.
 - 10.1.3. Aesthetics
 - 10.1.3.1. Coordinate design in advance with C&IT.
 - 10.1.3.2. Shop drawings must be approved in advance by C&IT.

11. Service and Support Recommendations

- 11.1. Ensure that digital signage players are ordered with 5-year depot warranty, as specified above.
- 11.2. Ensure that flat panel displays are ordered with 5-year depot warranty, as specified above.
- 11.3. Provide 5-year service and support plan covering labor, materials and shipping during 5-year warranty periods for digital signage players and displays.
- 11.4. Replace digital signage players every 5 years.
- 11.5. Replace digital signage displays as needed, typically every 5 to 10 years.
- 11.6. If location of signage is critical, ordering a spare player is recommended.

12. Block Diagram (next Page)

WSU Campus Digital Signage system

Block Diagram

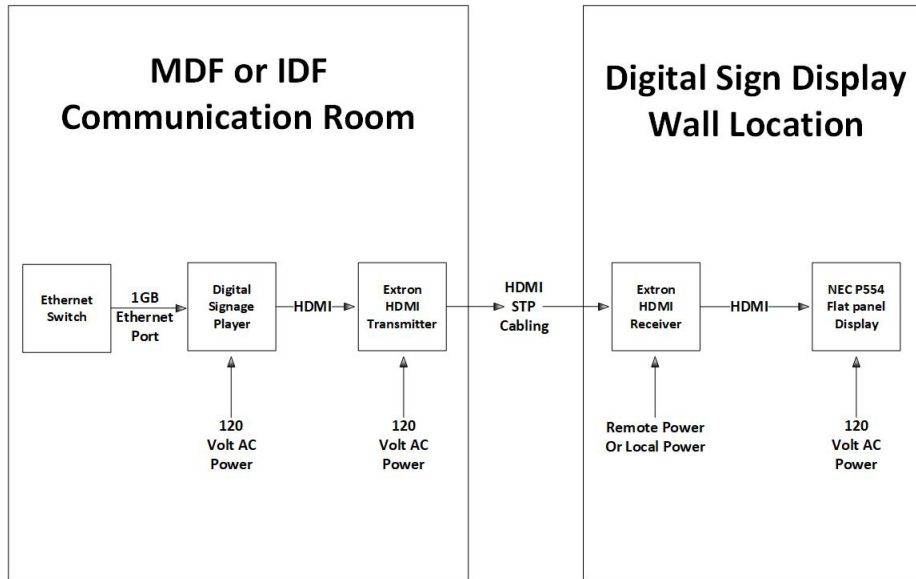

END OF SECTION 27600

ADDENDUM A - Hybrid Blue Light Phone (BLP) Components

General

1. All BLP components require submittals and CIT approval prior to purchase.
2. All requirements for BLPs called out in other sections of the Standards may apply and shall be coordinated into final design as required.
3. All BLP components shall be provided and installed by the contractor.
4. BLP components, part numbers and descriptions may change based on availability and final design.
 - a. CIT requires final review of all items prior to purchase.
 - b. Any items purchased without submittals, review and approval will be at the contractor's expense and not subject to reimbursement.
5. Hybrid Wiring Diagram:

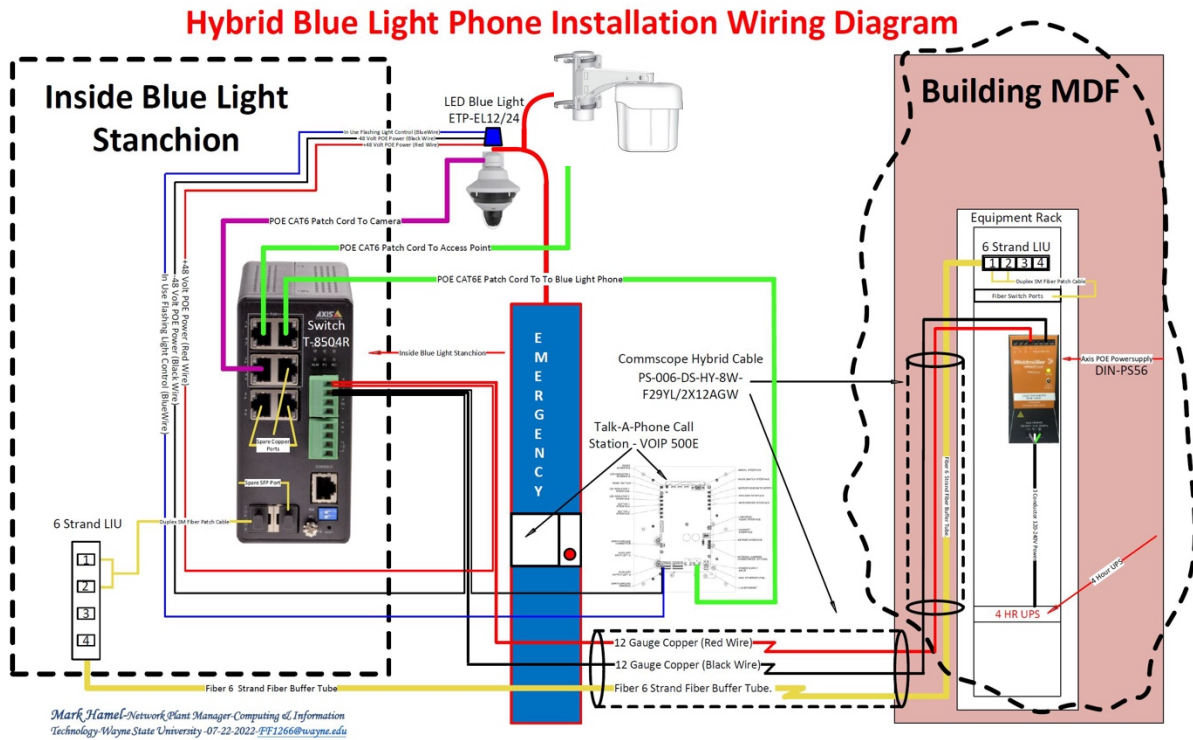

Components

1. Talk-A-Phone Call Station VOIP-500E
2. Talk-A-Phone ETP-MT/R Tower (Part number: ETP-MT/R-OP4P-PCS)
3. Talk-A-Phone LED Blue Light (Part Number: ETP-EL)
4. Axis Q6010-E IP Camera or better / approved by C&IT
5. Axis Q6075-E IP PTZ Camera or better / approved by C&IT
6. Axis T8504-R 4 Port Switch
7. Axis 56V 240W Power Supply
8. Axis Pendant Kit
9. Axis Threaded Coupler
10. Axis Attachment Kit
11. Cat6e 5m Patch Cord / Push Pull Patch Cable or Equivalent outdoor connection at camera depending on camera manufacturer.
12. Cat6e 1' Patch Cord for rack side
13. (2)- 1M Fiber Patch Cords with like connectors LC/LC / Rack side & Stanchion
14. Stanchion side - Din Rail with Construction Adhesive
15. IT closet side - Din Rail Kit
16. Commscope Hybrid S06L12F SM Fiber w/ 12 AWG (Part # P-004-DS-HY-8W-F29YL/2X12AWG) or Similar.
17. Small Fiber wall mounted LIU Termination Box for Stanchion and rack mounted LIU Loaded with bulk heads.
18. (2) Single Mode Network GBIC's / One for each end / Consult C&IT Network Engineer & Project Management for manufacturer type
19. LC Single Mode Connectors (Quantity to match fiber cable)
20. Underground conduit to BLP / Minimum 1"
21. Concrete mounting pad
22. Sonnet Tube Conduit Sleeve, Grounding and Concrete Industrial Plastics - Clear polycarbonate tubing – Part # 2.00X2.250X95
23. Any missing components are the responsibility of the installing contractor.

Top of BLP Example



Talk-A-Phone Part number: ETP-MT/R-OP4P-PCS

